



**THE ANNUAL NATIONAL ASSESSMENT OF 2014
DIAGNOSTIC REPORT
INTERMEDIATE AND SENIOR PHASES
MATHEMATICS**



basic education
Department:
Basic Education
REPUBLIC OF SOUTH AFRICA



ANNUAL NATIONAL ASSESSMENT

2014

DIAGNOSTIC REPORT

INTERMEDIATE AND SENIOR PHASES

MATHEMATICS

TABLE OF CONTENTS

	FOREWORD	3
1.	INTRODUCTION	4
2.	PURPOSE AND SCOPE OF THE REPORT	4
3.	METHOD	4
	PART A: DIAGNOSTIC ANALYSIS	7
4.	INTERMEDIATE PHASE	8
4.1	SUMMARY OF KEY FINDINGS	8
4.2	DETAILED ANALYSIS	13
5.	SENIOR PHASE (GRADE 9)	51
5.1	SUMMARY OF KEY FINDINGS	51
5.2	DETAILED ANALYSIS	53
	PART B: FRAMEWORKS FOR IMPROVEMENT	65
	PART C: DIAGNOSTIC ANALYSIS AT SCHOOL/DISTRICT LEVELS	81
	SUMMARY	88

FOREWORD



There is no doubt that in the four years that the Department of Basic Education (DBE) has been administering Annual National Assessment (ANA) the focus in the basic education sector has shifted in the right direction, viz. towards continuously improving the quality of teaching and learning. Every ANA cycle provides evidence of areas of improvement as well as areas that require special attention to improve learner performance in the key foundational skills of literacy and numeracy.

The next phase towards the improvement of educational quality in this sector is enhancing the effective utilisation of the assessment data at all levels of the system, particularly at the classroom level. There is need for a detailed analysis of the knowledge and skills that learners were able or not able to demonstrate in the ANA tests and use that evidence to inform all plans for intervention. But evidence must lead to appropriate action for it to result in the desired changes, hence the crucial value that the diagnostic report adds towards the utilisation of the ANA data to improve the quality of teaching and learning in schools.

The diagnostic report from the 2014 ANA cycle profiles the levels and quality of skills and knowledge that the assessment identified in the system. Evidently, some of the weaknesses that are identified were also raised in previous ANA cycles and new areas of challenge are profiled more sharply in 2014. ANA has added an empirical dimension to some of the concerns that require special attention.

The ANA 2014 diagnostic report, should be utilised fully to inform relevant decision-making in developing and implementing appropriate interventions to improve the quality of teaching and learning in basic education.

A handwritten signature in black ink, which appears to read 'Angie Matsie Motshekga'.

ANGIE MATSIE MOTSHEKGA, MP

MINISTER OF BASIC EDUCATION

2 FEBRUARY 2015

1. INTRODUCTION

The Annual National Assessment (ANA) was administered by the Department of Basic Education (DBE) country wide in Language and Mathematics on learners in Grades 1-6 and 9 in September 2014. Both public and state-funded independent schools took part in the assessment. ANA test results serve as a proxy for the quality of education at the General Education and Training (GET) Band in South Africa. Analysis of the knowledge and skills that learners were able or not able to demonstrate in the assessment shows that, while there has been an appreciable improvement in performance in the basic skills in both Language and Mathematics, a significant proportion of learners still experience challenges in providing responses to questions that require high order cognitive skills. In particular, learner performance in mathematics tends to decline progressively from the Intermediate to the Senior Phase.

The Diagnostic Report provides a detailed analysis of the knowledge and skills that learners displayed or failed to display in the tests that were administered in each grade and subject. The target audience for the report are teachers and School Management Teams (SMTs) in schools. However the information in the report will also be very valuable to district/circuit curriculum officials and subject advisors who need to provide support to schools in curriculum implementation. The report also presents findings that both provincial and national levels of the education system need to consider in monitoring provision of relevant resources to schools.

The Diagnostic Report is phase specific and comprises three separate documents. The first document is compiled for the Foundation Phase and contains analysis, findings and recommendations related to Home Language and Mathematics. For the Intermediate and Senior Phases there is one report for Mathematics and another for Home Language (HL) and First Additional Language (FAL). Each document has three parts viz, Part A: Diagnostic Analysis; Part B: Proposed Frameworks for Improvement; and, Part C: Diagnostic Analysis at school/district levels.

2. PURPOSE AND SCOPE OF THE REPORT

The purpose of the Diagnostic Report is to provide detailed evidence of the knowledge and skills that the analysis shows learners were able or not able to demonstrate in the ANA tests. The diagnostic evidence will inform appropriate interventions for a) teaching and learning, b) management of curriculum implementation, c) curriculum and management support at district/circuit level, and d) resource provision and monitoring at national and provincial levels. The report also provides SMTs with objective evidence to identify areas where individual teachers may need specific support in terms of various methods of facilitating learning and teaching.

3. METHOD

The Diagnostic Report was compiled by panels of teachers and subject advisors who were identified as specialists in Mathematics and Languages. The data that was used in compiling the report was obtained from marked scripts collected from representative samples of schools and learners, drawn from all nine provinces, that participated in Verification ANA in 2014.

For each subject and grade, item (question-by-question) analysis was conducted to identify the content knowledge and skills that learners were able or not able to demonstrate in the relevant tests. Analysis proceeded from calculation of basic descriptive statistics such as the mean, median, mode and range of scores obtained by learners, followed by a systematic interrogation of learner responses to identify common errors and strengths.

Specimens of typical errors made by learners were scanned and included in the report to illustrate possible knowledge “gaps” and common misunderstandings that need to be addressed in each grade and subject. In each content area, the panels suggested remediation strategies included also in this report that can be used to address the identified weaknesses in learner knowledge and skills.

The Proposed Framework for Improvement (Part B) suggests appropriate interventions for remediation at school, district, provincial and DBE levels. It is expected that an improvement plan with clear deliverables and timelines will be developed so that interventions can commence at the beginning of the school year.

The last part of the report is a suggestion on how schools and districts should analyse ANA and any other test data to derive useful information that must be utilised to address identified weaknesses, and ensure that every child in the system achieves learning outcomes of a high quality.

PART A

DIAGNOSTIC ANALYSIS



4. INTERMEDIATE PHASE

4.1 SUMMARY OF KEY FINDINGS

The key findings from the analysis have been summarised for the Intermediate and Senior Phases in two formats; firstly, in a histogram that shows how learner scores in each grade were distributed and, secondly, in tabular form that shows the areas of strength and weakness displayed by learners in each grade.

GRADE 4

The Overall performance of the sampled learners was at the “Elementary achievement” level (average of 36%). Distribution of learner percentage scores shown in the histogram below.

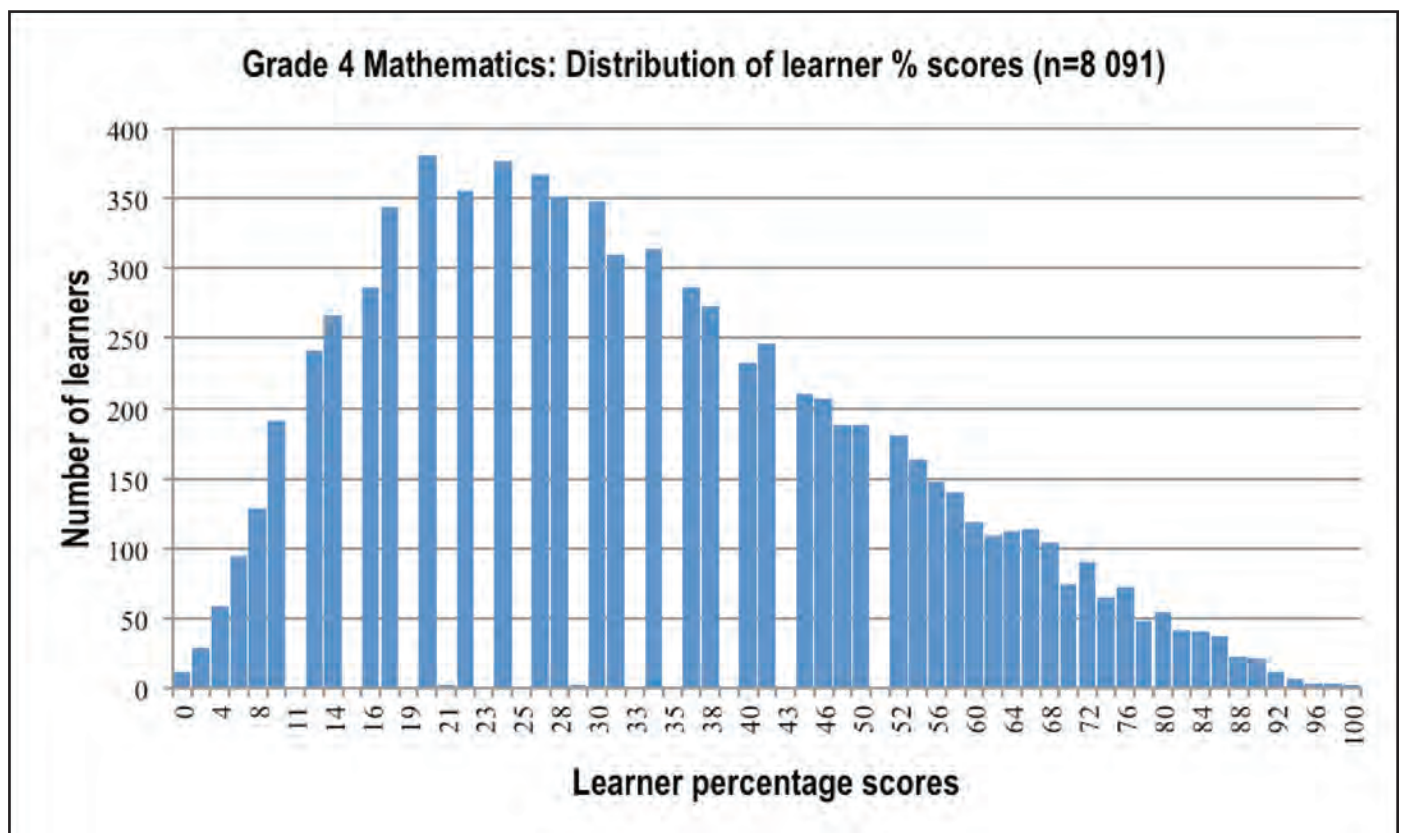

Figure 1.1: Grade 4 Mathematics: Distribution of learner % scores (n=8 091)

The learner scores in Grade 4 Mathematics ranged from 0% to 100% and the modal score (the score most frequently attained by learners) was 20%.

The specific areas of strength and weakness displayed by Grade 4 learners have been summarised in Table 1.1.

Table 1.1: Summary of learner strengths and weaknesses in Grade 4 Mathematics

AREAS OF WEAKNESS	AREAS OF STRENGTH
<p>Learner responses showed weaknesses in the following areas:</p> <ul style="list-style-type: none"> • Calculation of time intervals; • Identification of symmetry of 2-D shapes; • Solving problems on capacity; • Solving problems in financial contexts; • Comparing common fractions; • Solving problems involving grouping and sharing; • Division of whole numbers; • Determining input and output values; • Ability to work Number sentences; • Knowledge of Properties of 2-D shapes and 3-D objects; and, • Conversion of units in measurement. 	<p>Questions on the following areas were reasonably well answered:</p> <ul style="list-style-type: none"> • Place value of 4-digit whole numbers; • Multiples of 3; • Rounding off to the nearest 10; • Addition of whole numbers; • Subtraction of whole numbers; • Multiplication of whole numbers; • Numeric and geometric patterns; • Writing down the correct view of objects; • Reading time on time instruments; and, • Organising data using tally marks.

Compared to 2013 there were fewer areas of weakness. However, it should be noted that the following areas did not show an improvement:

- Calculation of time intervals;
- conversion of units in measurement;
- problem solving; and,
- division.

GRADE 5

The Overall, performance of the sampled learners was at the “Elementary achievement” level (average of 38%). The distribution of learner percentage scores is shown in the histogram.

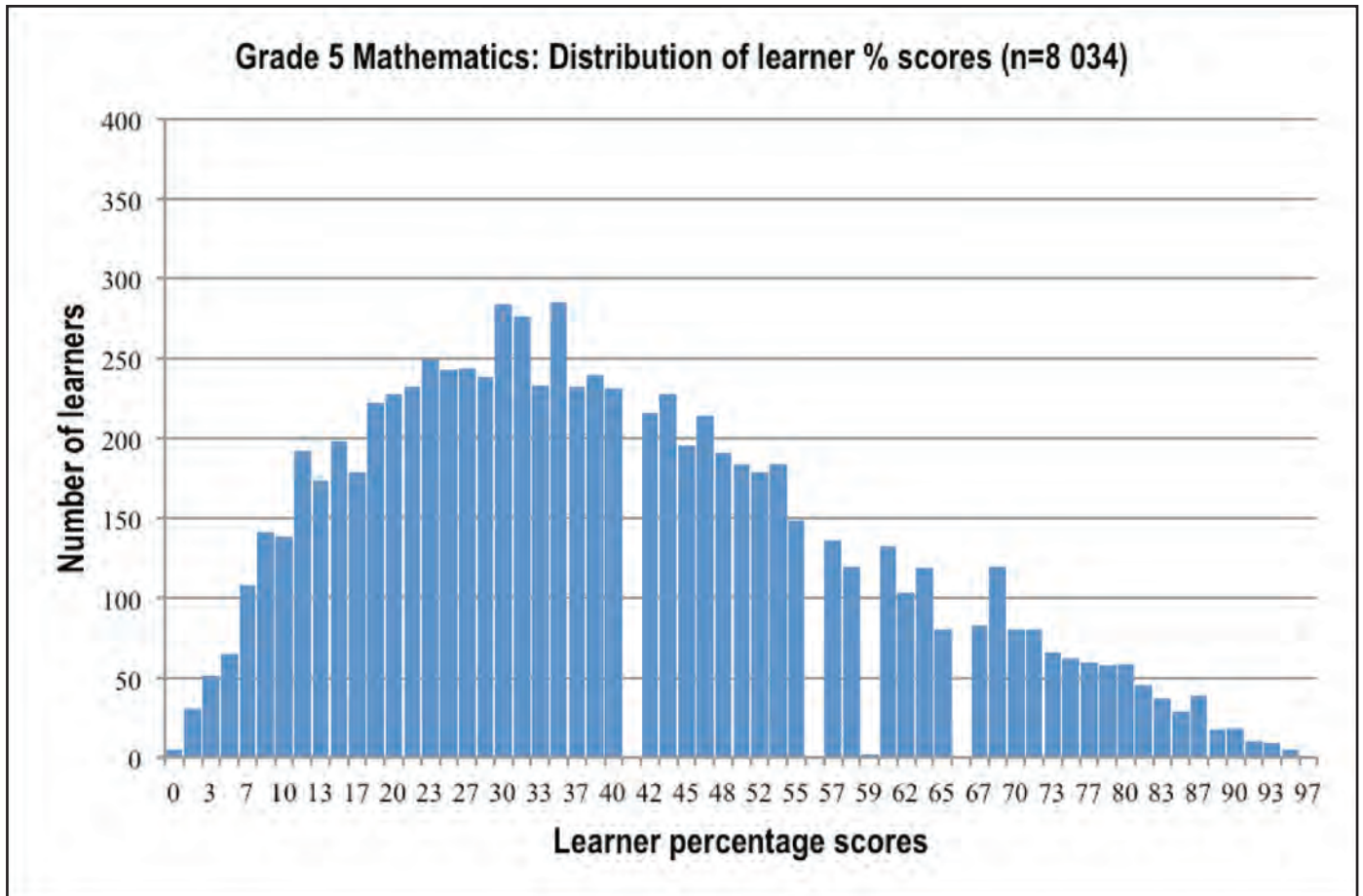

Figure 1.2: Grade 5 Mathematics: Distribution of learner % scores (n=8 034)

The learner scores in Grade 5 Mathematics ranged from 0% to 97% and the modal score (the score most frequently attained by learners) was 35%.

The specific areas of strength and weakness displayed by Grade 5 learners have been summarised in Table 1.2.

Table 1.2: Summary of learner strengths and weaknesses in Grade 5 Mathematics

AREAS OF WEAKNESS	AREAS OF STRENGTH
<p>Learner responses showed weaknesses in the following areas:</p> <ul style="list-style-type: none"> • Writing open number sentences; • Identifying multiples of 2-digit numbers; • Understanding number patterns; • Division of whole numbers by factor method; • Transformation of 2-D shapes; • Rounding off to the nearest 5; • Multiplication of 3-digit by 2-digit numbers; • Knowledge of properties of 2-D shapes and 3-D objects; • Calculation of time in hours and minutes; • Arranging units of measurements from the least to the most; and, • Calculating the perimeter of rectangular objects. 	<p>Questions on the following areas were reasonably well answered:</p> <ul style="list-style-type: none"> • Critically reading and interpreting data from bar graphs; • Writing down the correct view of objects; • Solving problems in financial contexts; • Solving problems that involve temperature; • Addition of fractions; and, • Subtraction of whole numbers.

Compared to 2013 there was a slight improvement in performance with fewer areas of weaknesses. The following areas did not show improvement:

- Ability to respond to non-routine problem solving;
- Ability to do division;
- Use of commutative and distributive properties;
- Ability to calculate fractions;
- Knowledge of multiples of number;
- Knowledge of factors;
- Ability to write number sentences;
- Ability to extend number patterns; and,
- Knowledge of properties of 3-D objects.

GRADE 6

The Overall performance of the sampled learners was at the “Moderate achievement” level (average of 43%). The distribution of learner percentage scores is shown in the histogram.

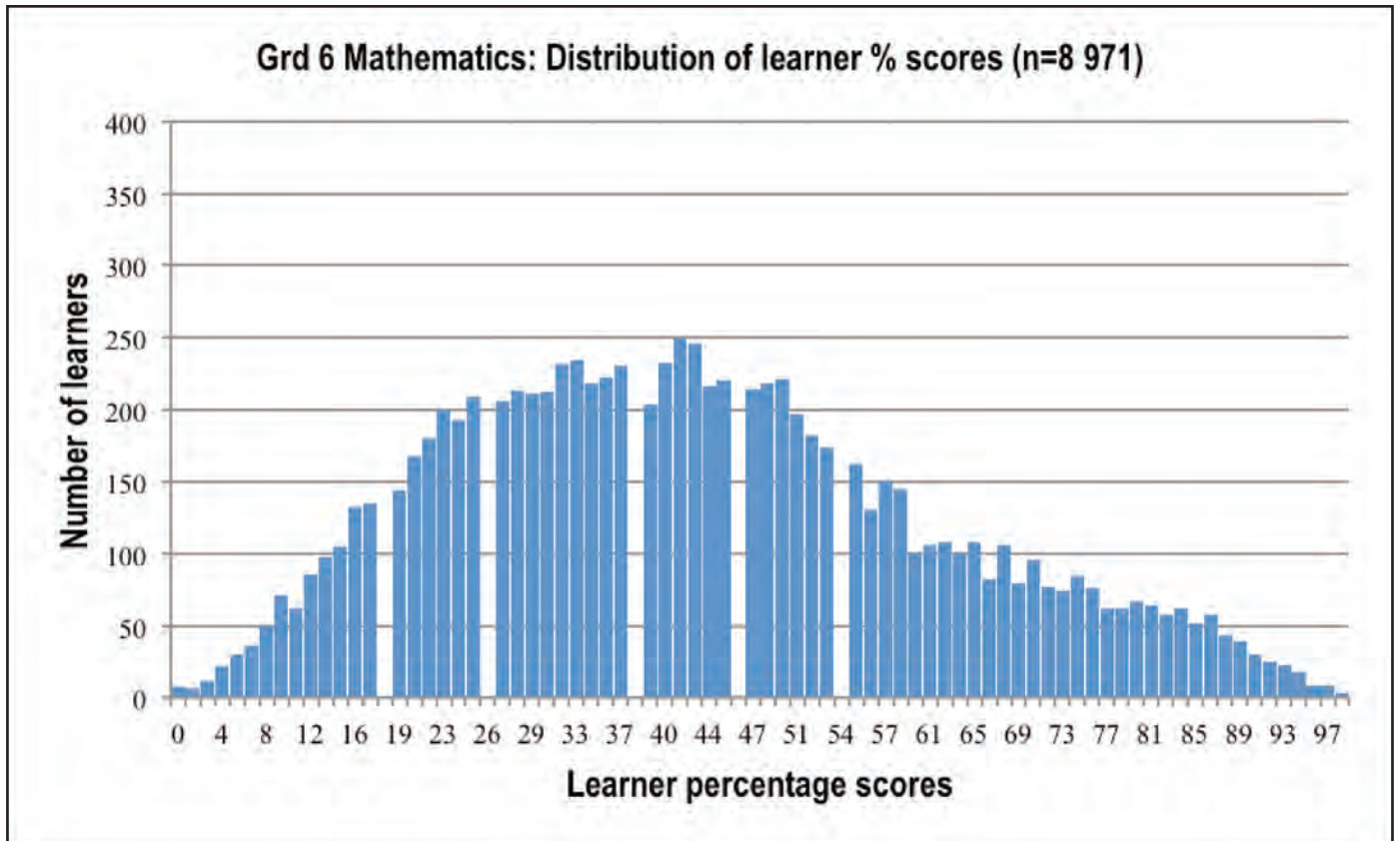

Figure 1.3: Grade 6 Mathematics: Distribution of learner % scores (n=8 971)

The learner scores in Grade 6 Mathematics ranged from 0% to 100% and the modal score (the score most frequently attained by learners) was 41%.

The specific areas of strength and weakness displayed by Grade 6 learners have been summarised in Table 1.3.

Table 1.3: Summary of learner strengths and weaknesses in Grade 6 mathematics

AREAS OF WEAKNESS	AREAS OF STRENGTH
<p>Learner responses showed weaknesses in the following areas:</p> <ul style="list-style-type: none"> • Time zone maps and calculating time; • Similarities and differences between rectangle and parallelogram; • Conversions of units in measurement; • Problem solving number pattern; • Multiples of single digit numbers; • Grouping and equal sharing with remainders; • Long division of whole 4-digit numbers by 2-digit numbers; • Numeric patterns; • Properties of 2-D shapes and 3-D objects; and, • Multiplication of whole 4-digit numbers by 2-digit numbers. 	<p>Questions on the following areas were reasonably well answered:</p> <ul style="list-style-type: none"> • Interpretation of data from pie charts • Reading correct measurements from a scale • Addition and subtraction of whole numbers with at least 5-digit numbers; • Calculating the mode of a given set of numbers; • Addition and subtraction of mixed numbers; • Subtraction of decimal fractions; • Counting backwards in decimal; and, • Identifying input and output values using flow diagram.

Compared to 2013 there was a slight improvement in performance with fewer areas of weaknesses, although the following areas did not show an improvement:

- Understanding of time zones;
- Knowledge of properties of 3-D objects;
- Ability to respond to non-routine questions;
- Ability to do division of numbers;
- Knowledge of multiples of numbers;
- Ability to write number sentences,
- Ability to identify or write number patterns.

Comparing the performance from Grade 4 to Grade 6, it was observed that the distribution of learner scores in Mathematics progressively shifted toward the lower end of the scale. The reasons for this decline in performance across the grades must be mitigated and addressed.

4.2 DETAILED DIAGNOSTIC ANALYSIS

Specific skills that were assessed, a detailed analysis, the findings, specimens of learner responses, possible explanations for observed performance and recommended remediation interventions per grade have been presented in this section. A detailed analysis of the weaknesses, with specimens of typical learner responses, has also been presented in this section. For each identified weakness, possible explanations were given and recommendations are made for possible remediation options.

4.2.1 CONTENT AREAS, KNOWLEDGE AND SKILLS ASSESSED

The following content areas, knowledge and skills were assessed in the Grade 4 test.

a) Numbers, Operations & Relationships:

Assessed skills in this area included:- knowledge of place value(s) of numbers;

- knowledge of the technique of rounding off given numbers to the specified nearest number; ability to work with Operations (Addition, Subtraction, Multiplication and Division), solving problems in given financial contexts;
- knowledge of and ability to work with properties of numbers;
- knowledge of and ability to do calculations based on calculations with fractions; and,
- ability to identify and distinguish between multiples and factors of numbers.

b) Patterns, Functions & Algebra:

Knowledge and skills that learners had to demonstrate in this area included:-

- ability to write number sentences;
- demonstrating ability to solve problems that require knowledge of 'input and output values' and ability to identify Numeric and Geometric patterns.

c) Space & Shape:

Learners had to demonstrate knowledge of:-

- properties of 3-D objects;
- ability to locate position of objects in 2-D and 3-D space and skills in viewing and transformation of objects, and the ability to recognise symmetry in 2-D shapes.

d) Measurement:

Learners had to demonstrate knowledge of and skills in calculating quantities such as mass, length, perimeter, temperature and volume of objects. They were also assessed on ability to calculate time and show how to do conversions in expressing measurement in different forms.

e) Data Handling:

Data handling skills that were assessed included ability to read, organise, and interpret pie charts.

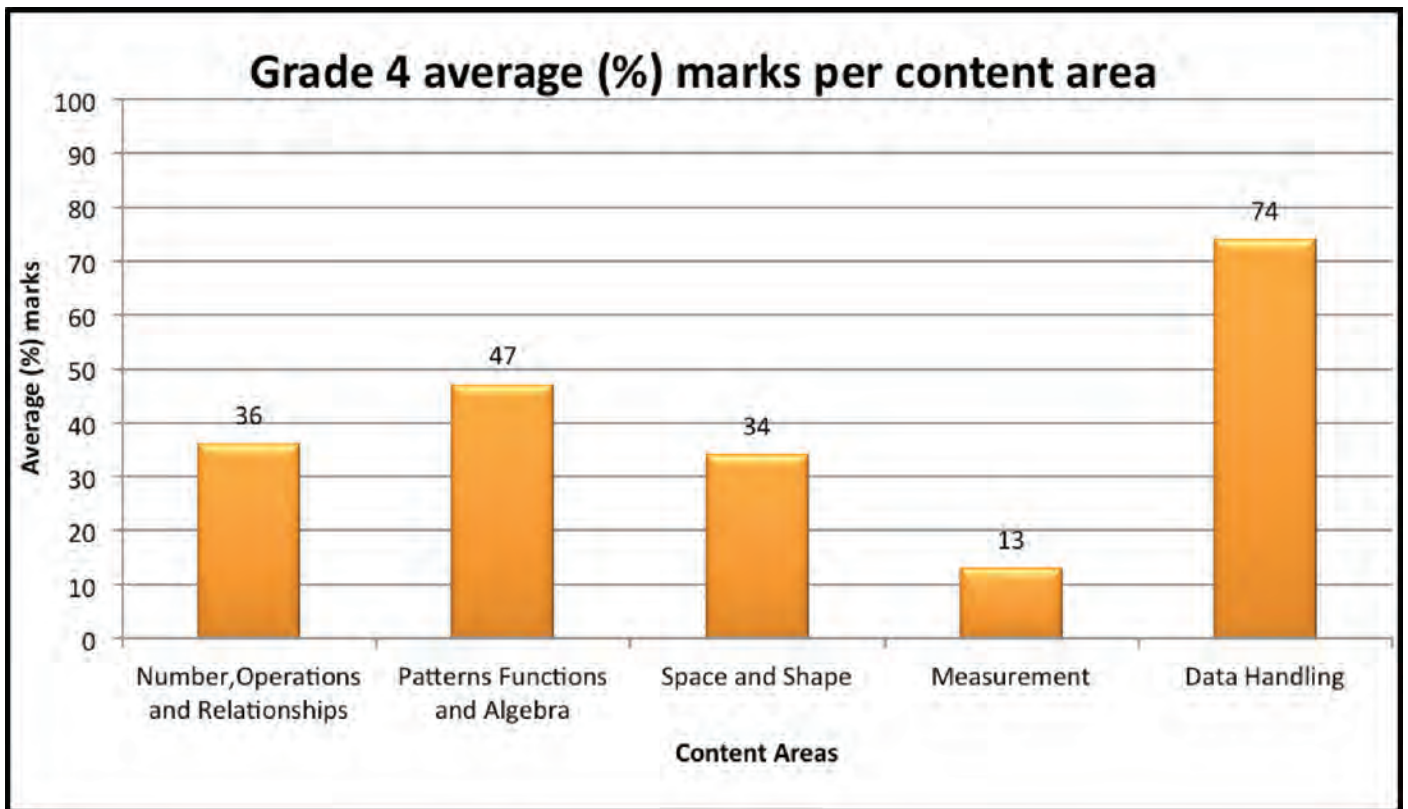

Figure 1.4: Learner performance in the various content areas

The data in Figure 1.4 shows that Grade 4 learners experienced the greatest difficulty in responding to questions on “Measurement”. The second area of marked difficulty, as experienced by learners, was “Space and Shape”. Learners found questions on “Numbers, Operations and Relationships” relatively easier to respond to and learners performed exceptionally well in “Data Handling”, followed by “Patterns, Functions and Algebra”. This pattern of performance is similar to the performance of learners in the ANA of 2013, suggesting that the remediation strategies for Grade 4 not made a meaningful impact on performance.

NUMBERS, OPERATIONS AND RELATIONSHIPS

In this content area it was observed that learners performed well in addition, subtraction, multiplication, place value and rounding off. Specific learning weaknesses were in division, identifying common fractions and properties of whole numbers.

a) Common Fractions

At Grade 4 level, learners are expected to be familiar with different diagrams or formats fractions, as well as performing calculations of fractions and using common denominators. Learners seem to be able to add fractions, but they experienced difficulty in understanding fractions drawn in two different shapes. An example of this is illustrated below.

Look at the diagrams and then answer Questions

Is the shaded fraction in diagram A equal to the shaded fraction in diagram B? No. ~~✓~~ ✗

Diagram A



Diagram B



What fraction of Diagram A is not shaded?

3/4 angle. ~~✓~~ ✗

Typically, the common error was that learners were unable to recognise and interpret equivalent common fractions when represented in different diagram forms. Diagram A represented quarters in a rectangular fraction form, whereas Diagram B represented quarters in a triangular fraction form. Learners were unable to recognise the link between the two diagrams.

Remediation

In this area, the possible remediation would be for learners to work with region models (circles and other geometric shapes), length and set models, to enhance their knowledge of equivalent fractions represented in different forms. The different shapes should be partitioned and shaded to represent fractions which are equal to each other. This can then be extended to compare the equivalence of various shaded fractions drawn in different shapes. An illustration of this is indicated below.

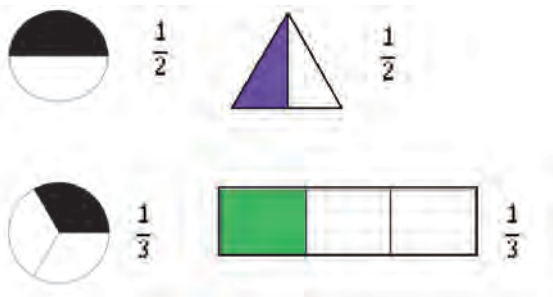

b) Division

Grade 4 learners are expected to use a variety of techniques to calculate division. The expected methods used were estimation, building-up and breaking-down and rounding off. A high percentage of learners could not solve a problem with a 3-digit number divided by a 1-digit number. The following is an example of a 3-digit number divided by a 1-digit number.

$$852 \div 6$$

$$\begin{array}{r} 852 \\ \hline 6 \\ \hline 228 \end{array}$$

Learners experience a problem with the setting out of the division problem. In this case learners set out the problem as an addition problem instead of a division problem. The correct answer was 142. The above example shows that learners incorrectly added 6 to 852 and got an answer of 228.

Remediation

A possible strategy could be to divide 852 by 2 first, and then divide by 3, as both are factors of 6.

The working out should be as follows:

$$852 \div 6$$

$$= 852 \div 2 \div 3$$

$$= 426 \div 3$$

$$= 142$$

Alternatively it could be calculated by “breaking-down” the 3-digit number.

$$852 \div 6$$

$$= (840 + 12) \div 6$$

$$= 840 \div 6 + 12 \div 6$$

$$= 140 + 2$$

$$= 142$$

$$\text{therefore } 852 \div 6 = 142$$

Building awareness of the multiples of 6, namely, 100×6 , 10×6 , and 20×6 , can also be emphasised.

PATTERNS, FUNCTIONS AND ALGEBRA

In this content area, it was observed that learners performed well in symmetry, numeric patterns and geometric patterns. Learners experienced difficulty with number sentences and flow diagrams.

a) Number sentences

In Grade 4, learners are expected to be able to work with number sentences in various forms of representation. One expected form is to write a number sentence which has been specified in a word problem. In the example below, learners were required to write a number sentence to describe a problem situation.

Write a number sentence, for the word sentence below.

Twelve divided by three is equal to eight divided by two.

The image shows a handwritten number sentence $12 \div 3 = 4$ written in blue ink. A red checkmark is placed to the right of the equation, and a purple 'X' is placed to the right of the checkmark. A green checkmark is also visible below the line.

A typical error observed was that part of the sentence was used to formulate a number sentence and the answer was calculated. The full number sentence was not completed. The correct number sentence is $12 \div 3 = 8 \div 2$. In broader terms, it could be inferred that learners did not fully understand the process of converting words into symbols, and get this is necessary skill for their transition from arithmetic to algebra. In the problem above, learners were able to convert part of the word problem into a number sentence. However, instead of providing the second part of the number sentence, they provided the answer to the number sentence. This implies that learners do not understand the instruction. The concept is understood but not fully.

Remediation

A possible remediation strategy at this level is to teach learners to understand and interpret mathematical terminology by identifying key words and replacing them with numbers and operation signs.

For example: Twelve divided by three is equal to eight divided by two.



The symbols showing greater than, less than and is equal to, must be explained in order to complete number sentences.

Twenty divided by five is greater than fifteen divided by five.



In addition, practice must be given in writing number sentences similar to the specimen.

b) Input and output values

At this level learners should be able to use flow diagrams to understand the use and connection between input and output values and the use of the rule or pattern. An important skill necessary for learners is that of solving how flow diagrams using multiple operations. In the example below, learners were required to complete the flow diagram given the input value and the rule, which includes multiple operations.

Complete the following flow diagram.

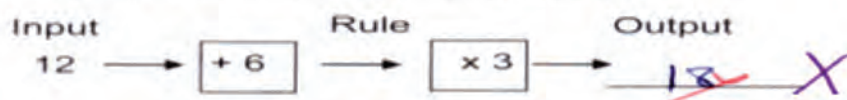

In the above example the input value is 12, and the rule is to add 6 and multiply by 3, to calculate the final output value. The answer for the final output is 54. A high percentage of learners responded by multiplying 6 by 3, which showed a lack of understanding of how to apply the rule.

Remediation

The purpose of this remediation strategy is to place emphasis on the order of the first input value producing the first output value, and the second input value producing the second output value. In addition, learners should be exposed to the various techniques used to calculate input and output values, as part of their mental maths programme throughout the year. An illustrated example is provided below.

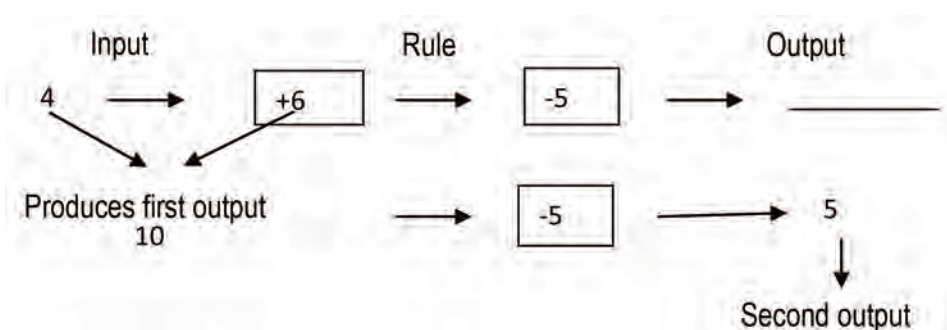

In the example above learners were given an input of 4, to work towards getting an output of 5. The rule was to find values that could first be added, and then subtracted. The solution is worked out by trial and error. The number to be added in this example was 6 and the number to be subtracted was 5. Learners should be given similar examples where input and output values are given, and have to work out the missing numbers that would fit the rule.

c) Geometric patterns

At the start of the Intermediate Phase, learners are expected to have skills in looking for relationships or rules of patterns by repeating patterns or increasing and decreasing patterns in different ways. In this assessment, it was observed that learners could not extend geometric patterns by looking for relationships or rules of patterns, as prescribed in the curriculum. An important skill in this topic is for learners to know the difference between the “repeating” and “growing” patterns. The repeated pattern is a more familiar skill for learning in the Foundation Phase. In Grade 4 there is an increasing demand for learners to apply “repeating” and “growing” geometric patterns. In the question below learners were required to investigate and extend the geometric pattern by looking for a relationship or rule of the pattern represented in diagram form.

How many circles will be there in the next diagram if the pattern is continued?



In the example above, a high percentage of learners did not recognise that this was a “growing” and not a “repeating” geometric pattern. Hence they indicated only 1 circle (repeating pattern) instead of 7 circles (growing pattern).

Remediation

A possible strategy is to teach patterns in which the shapes increase or decrease in different ways. Geometric patterns should be linked with the number patterns to enhance understanding and in this way learners are able to visualize the pattern in number form and extend the sequence.

Example 1:

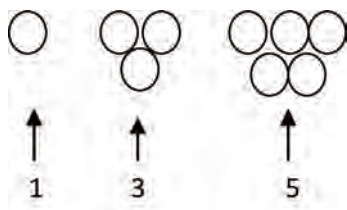

Example 2:

Write the number of squares under each “growing” diagram pattern which will assist in drawing the next diagrams to complete the geometric pattern.

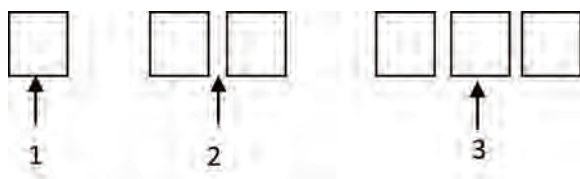

Learners need to be given more examples like the one above to practise finding “growing” patterns that may be increasing or decreasing. This is an important basic skill for learners to find patterns and missing terms when they work with sequences and series of numbers in later grades. Finding growing patterns and missing terms is an important basic skill for learners because it will prepare or help them in later grades when working with sequences and series of numbers.

SPACE AND SHAPE

In this content area, it was observed that learners performed well in naming 2-D shapes, as well as viewing objects. A specific weakness observed was identifying the number of faces in a 3-D object.

a) Properties of 3-D objects

Learners were expected to name 2-D shapes and 3-D objects, as well as identify the faces of 3-D objects. Learners could easily identify the name of the 3-D object. However, the common error was an inability to count the number of faces. Instead, most learners named the faces according to 2-D shapes. In the example below learners had to count the number of faces of a 3-D object.

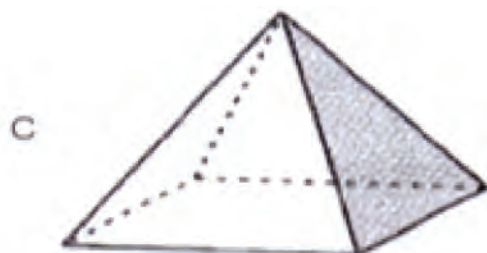

The 3-D object marked C has triangular faces

Questions of this type require high order geometric skills as well as knowledge of faces, vertices and edges. A typical error was the misinterpretation of the question by naming the faces of the shape, instead of identifying the correct number of faces. In the example, the 3-D object is a pyramid and the correct answer is 5 faces. A high percentage of learners reduced the complexity of the problem to a 2-D shape, which they are more familiar with. Hence, the common response was a triangle.

Remediation

Remediation must focus on progressing shifting learners from 2-D shapes to understanding properties of 3-D objects. To assist learners, a more concrete hands-on approach of making 3-D objects using cut-out polygons in identifying and counting the faces is required. Mathematics terminology should be incorporated when teaching 3-D objects.

Alternatively, revise properties of 2-D shapes and link these concepts to faces of 3-D objects.

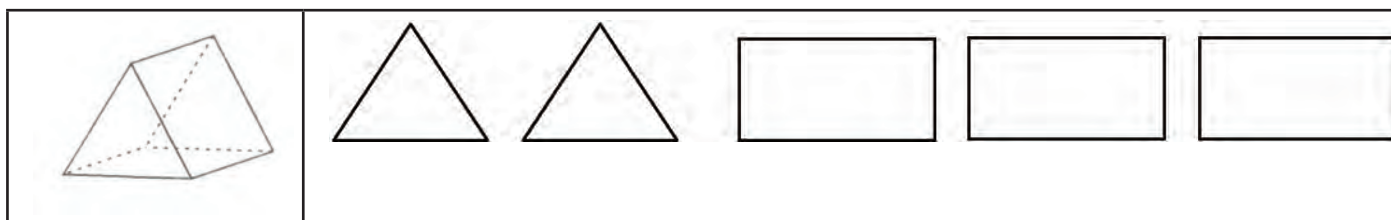

Triangular prism = 2 triangular faces + 3 rectangular faces

b) Properties of 2-D shapes

Learners are required to be familiar with characteristics and properties of regular and irregular 2-D shapes. Although learners could easily name the 2-D shapes, they experienced difficulty in identifying regular and irregular 2-D shapes. In the example below learners were required to recognize and name a 2-D shape.

What kind of shape is the given 2-D shape? State whether it is a regular or irregular shape.













← regular ~~X~~
 6 part and 2-D ~~X~~ shape.

Common errors observed were that learners counted the number of sides, instead of naming the 2-D shape, and could not identify the shape. In the example above the correct answer was a hexagon and the shape was irregular.

Remediation

Emphasis must be placed on making learners aware that regular shapes have equal lengths and irregular 2-D shapes have different lengths. A range of different 2-D shapes, both regular and irregular, should be taught, placing emphasis on counting the number of sides, in order to name the 2-D shapes. A simple table, as displayed below, could be used as a possible strategy to remediate skills in identifying regular and irregular shapes.

Regular and Irregular Polygons

Name	Regular	Irregular	
Triangle			3 sides
Quadrilateral			4 sides
Pentagon			5 sides
Hexagon			6 sides
Octagon			8 sides

In the table above, regular and irregular shapes are provided. Using the table, above learners should be shown regular and irregular shapes of triangles, quadrilaterals, pentagons, hexagons and octagons. The number of sides for each shape should be indicated. The table can be used to show similarities and differences between different regular and irregular shapes. For example, learners can observe differences between a regular quadrilateral and a regular pentagon.

MEASUREMENT

In this content area, it was observed that learners performed well in reading time from an analogue clock. However, specific weaknesses were identified in solving measurement problems in contexts. Within a specific context, learners had to convert between centimetres (cm) and metres (m) and calculate time intervals.

a) Time

By Grade 4, learners are expected to read, tell and write time, as well as solve problems in context. They are required to do calculations of time intervals, where time is given in minutes and hours. It was observed that learners were able to record time easily on the clock face, but found it difficult to work with time intervals in an “everyday” problem-solving context. In the example below, the question asked was to calculate the time taken when travelling between Town D and Town G, as drawn on the time line.

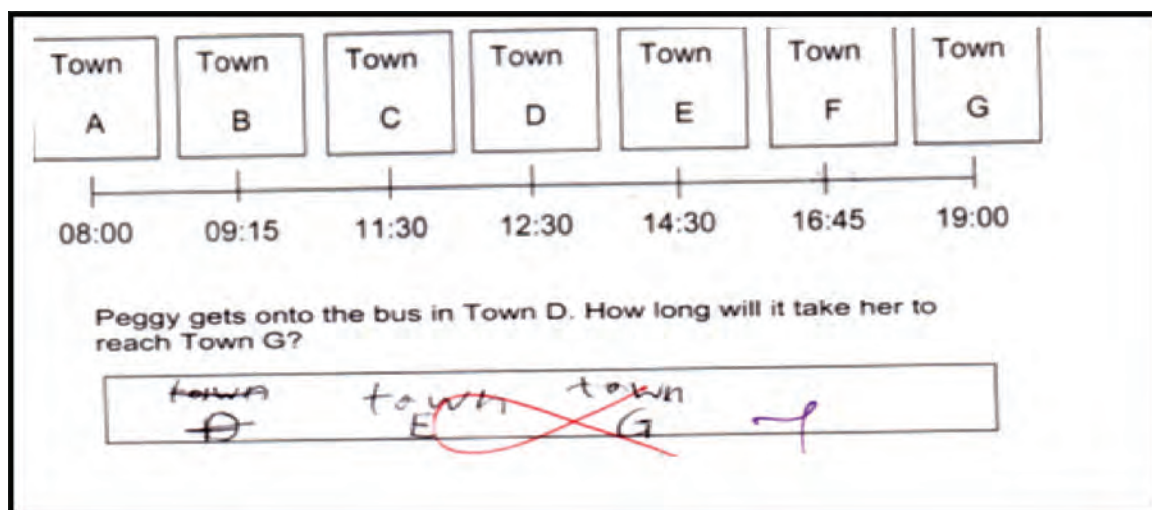

In the example above the correct answer is $6\frac{1}{2}$ hours. Learners had to know where to start as well as where to end, and do calculations. A high percentage of learners could not calculate the time intervals using a time line. Many learners named the towns, which reflected an inability to distinguish between time points (names of towns) and calculating time intervals. The calculation of time intervals is just an extension of reading time from different representations (analogue, digital and timeline).

Remediation

The purpose of this remediation is to make learners aware of calculating time intervals given in various forms, including using time lines in a problem-solving context. The example outlines steps to assist learners in calculating time between given time intervals.

06:40 to 10:20 is 3 hours 40 minutes

Step 1: 06:40 to 07:00 → 20 minutes

Step 2: 07:00 to 10:00 → 3 hours

Step 3: 10:00 to 10:20 → 20 minutes

Step 4: Total: 20 minutes + 3 hours + 20 minutes = 3 hours 40 minutes

b) Capacity/volume

Grade 4 learners are expected to use measuring instruments, convert between units, as well as calculate the capacity of objects in a problem-solving context. It was observed that learners could not calculate the capacity of a given object in context.

In the example below given. Learners were asked to calculate capacity by determining how many liters of coke were bought. They were regarded to multiply 1,5 l by 5 bottles and get a answer of the 500ml.

Merle's mum bought 5 bottles of Cola, shown below, for her party.



How many litres of Cola did she buy?

1,5 l ✓ X

Most learners did not read the capacity information correctly and therefore did not know how to solve the problem. Similar to the word problems, learners found it difficult to solve problems in context. Learners wrote the capacity as indicated on the label of the bottle as the answer.

Remediation

The teaching of word problems must be done systematically, as prescribed in Numbers, Operations and Relationships. Solving capacity problems is an important skill in solving “everyday” problems. Practical demonstrations can also build awareness and consolidate learners’ understanding of capacity/volume.

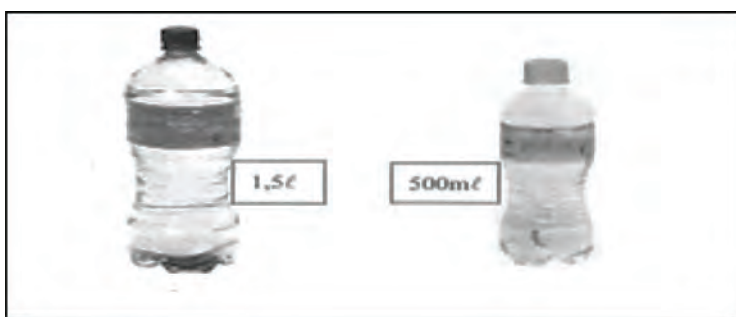

In the picture above learners can be made aware that 500 ml means half of a litre and 1,5 l means 1 and a half litres. Thus 0,5 is another way of writing 500 ml. Further examples of “real world” objects should be used to consolidate awareness of capacity.

DATA HANDLING

In this content area it was observed that learners performed very well in organising data and analysing data. A specific weakness area observed was that learners misrepresented items as tally marks and incorrectly completed frequencies.

a) Collect data using tally marks and tables for recording

Grade 4 learners were required to collect and organise data, as well as represent, analyse, interpret and report on data. The learners demonstrated good understanding of knowledge elements in this content area. Read and interpret data from bar graphs. In the example below learners had to complete a given table using tally marks and filling in the frequency.

Learners had to link information from a pie chart to a tally table. The first row was completed so that the learners could follow the sequence. In the second row the tally marks and the frequency were required. The correct answer was 15. A typical error was that learners did not know how to correctly draw 5 items as:

Example: A frequency table showing 5, 10 and 15 items.

Tally Marks	Frequency
HHH	5
HHH HHH	10
HHH HHH HHH	15

Remediation

Educators should focus on representing 5, 10 and 15 items using tally marks. Recording data using tally marks should be emphasised and demonstrated correctly. Learners should also be exposed to the correct use of Mathematics terminology.

In the Intermediate Phase, the use of tallies is an important organising tool in data handling. A recommendation would be to expose learners, who have mastered the correct representation, to solve tally problems in different contexts.

HHH

4.2.2 CONTENT AREAS, KNOWLEDGE AND SKILLS ASSESSED

The following content areas, knowledge and skills were assessed in the Grade 5 test.

a) Numbers, Operations & Relationships:

Assessed skills in this area included:-

- ability to count to at least 10 000;
- knowledge of place value(s) of numbers;
- knowledge of the technique of rounding off given numbers to the specified nearest number;
- ability to work with Operations (Addition, Subtraction, Multiplication and Division), solving money problems in given financial contexts;
- knowledge of and ability to work with properties of numbers; and
- knowledge of and ability to do calculations based on ratio(s) and fractions; ability to identify and distinguish between multiples and factors of numbers.

b) Patterns, Functions & Algebra:

Knowledge and skills that learners had to demonstrate in this area included:- ability to write number sentences; demonstrating ability to solve problems that require knowledge of 'input and output values' and ability to identify Numeric and Geometric patterns.

c) Space & Shape:

Learners had to demonstrate knowledge of properties of 3-D objects; ability to locate position of objects in 2-D and 3-D space and skills in viewing and transformation of objects.

d) Measurement:

Learners had to demonstrate knowledge of and skills in calculating quantities such as mass, length, perimeter, temperature and volume of objects. They were also assessed on ability to calculate time and show how to do conversions in expressing measurement in different forms.

e) Data Handling:

Data handling skills that were assessed included ability to read and analyse bar-graphs.

The performance of learners (average % marks) in the various content areas has been summarised in Figure 1.5.

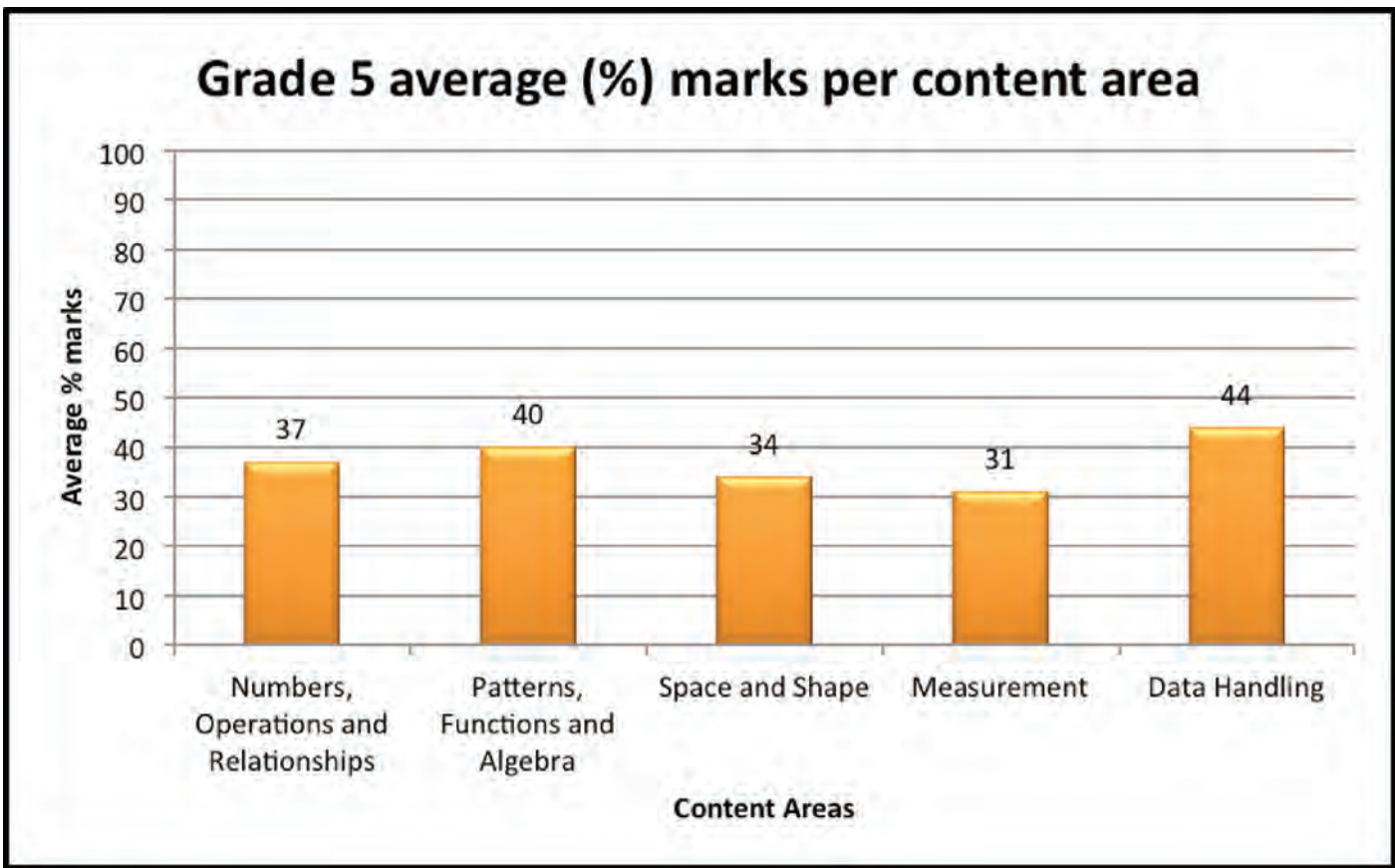

Figure 1.5: Learner performance in the various content areas

As shown in Figure 1.5, Grade 5 learners experienced the greatest difficulty in responding to questions on “Measurement” as indicated by the lowest average percentage marks (31%). The second area of marked difficulty to the learners was “Space and shape” with 34% average percentage marks. Learners found questions on “Data Handling”, “Patterns, Functions and Algebra” and “Numbers, Operations and Relationships” relatively easier to respond to as reflected in higher average percentage marks of 44%, 40% and 37%, respectively. This pattern of performance has not changed much from 2013, suggesting that the remediation strategies that were made for Grade 5 then need to be further strengthened.

A detailed analysis of the knowledge and skills that learners demonstrated in each content area is reported in the next sections.

NUMBERS, OPERATIONS AND RELATIONSHIPS

In this content area it was observed that learners performed relatively well in solving financial problems, recognising the place value of digits in whole numbers to at least 6-digit numbers, addition and subtraction of whole numbers and fractions. However, common errors were experienced in determining factors of numbers, identifying multiples of numbers, identifying equivalent fractions, knowledge of properties of numbers, ability to do multiplication and division of whole numbers and fractions, and solving non-routine problems.

Specific examples of areas in which learner performance was particularly unsatisfactory have been discussed in detail in the following sections.

a) Multiplication

In Grade 5 learners are expected demonstrate knowledge and skills in multiplying a 3-digit number with a 2-digit whole number. The skill assessed in this section was the ability to use either the vertical column method, breaking-down or building-up method in multiplication. The common error made by learners was multiplying the tens in the multiplier as a unit. A specific observation was that learners were unable to place the digits from the multiplier correctly according to place value. Consequently, the tens in the multiplier were often multiplied as a unit. Below is an example which required the multiplying a 3-digit number with a 2-digit number skill, using any appropriate method.

456 x 64

The image shows three handwritten multiplication problems for 456 x 64. Each problem shows the multiplicand 456 and the multiplier 64. The student has broken down the multiplier 64 into 6 and 4. In the first method, 456 is multiplied by 4 to get 1824, and then 456 is multiplied by 6 to get 2736. The final product is 29184. In the second method, 456 is multiplied by 4 to get 1824, and then 456 is multiplied by 6 to get 2736. The final product is 29184. In the third method, 456 is multiplied by 4 to get 1824, and then 456 is multiplied by 6 to get 2736. The final product is 29184. All methods show a common error where the multiplier 64 is broken down into 6 and 4, instead of 60 and 4.

In the example above, the multiplier is 64 and the multiplicand is 456. The product would be 29 184. The error was that the breaking-down technique was incorrectly applied. Learners erroneously broke down 64 into 6 and 4, instead of 60 and 4. The breaking-down technique requires the understanding of 'place value'. Although it was observed that there was some understanding of the breaking-down technique, it would appear that the main problem is in the misunderstanding of place value.

Remediation

In order to remediate common errors in multiplication made by learners, greater focus must be placed on good knowledge of multiples and factors and what distinguishes the two. Part of the remediation strategy should include use of mental mathematics.

To help learners gain a firm understanding of "place value", the breaking-down method is one strategy that can be used to apply and thus consolidate the understanding of key concepts.

Below is an illustration of the breaking-down method and how it helps learners grow familiar with identifying hundred, tens and units and thus deepen understanding of the concept of 'place value'.

Example

Applying the breaking-down method to calculate the product of the two numbers, 234 and 34:-

$$\begin{aligned} &234 \times 34 \\ &= (200 + 30 + 4) \times (30 + 4) \\ &= 6\,000 + 800 + 900 + 120 + 120 + 16 \\ &= 7\,956 \end{aligned}$$

Discussion of "place value" can then be taken around the following observations:-

- The number "2" in 234 is placed in the hundreds and its "place value" is 2×100 or 200
- The number "3" in 234 is placed in the tens and its "place value" is 3×10 or 30
- The number "4" in 234 is placed in the units and its "place value" is 4×1 or 4

It is important to demonstrate to learners that division and multiplication are inverse operations, and they can be used to confirm the correctness of the answer. For instance, dividing 7 956 by 34 must give 234 as the answer otherwise the multiplication is incorrect. Similarly, dividing 7 956 by 234 must give 34 as the answer.

b) Rounding off to the nearest 5

By Grade 5 learners are expected to demonstrate relevant knowledge and skills in using the rules for rounding off to the nearest 5. This is an extension of rounding off to the nearest 10, 100 and 1 000 which is done in Grade 4. A specific observation was made where learners used the technique of rounding off to the nearest ten when they had been asked to round off to the nearest 5. An example of this is illustrated below.

462 473 rounded off to the nearest 5 is ...

(A)	462 470	
B	462 475	
C	462 479	
D	462 480	

In the above example, a high percentage of learners selected 462 470 apparently because they rounded off to the nearest 10 instead of rounding off to the nearest 5. The correct answer when rounding off 462 473 to the nearest 5 is 462 475. Since rounding off to the nearest 5 is done for the first time in the Intermediate Phase in Grade 5, it could be inferred that the learners either did not fully understand how to apply the rule correctly or they lacked exposure to this technique.

Remediation

A possible remediation for teaching and revising the understanding of the technique of rounding off is to use a number line displaying the rules of rounding. The following example may help to explain rounding off to the nearest 5. The number that needs to be rounded off should be highlighted.

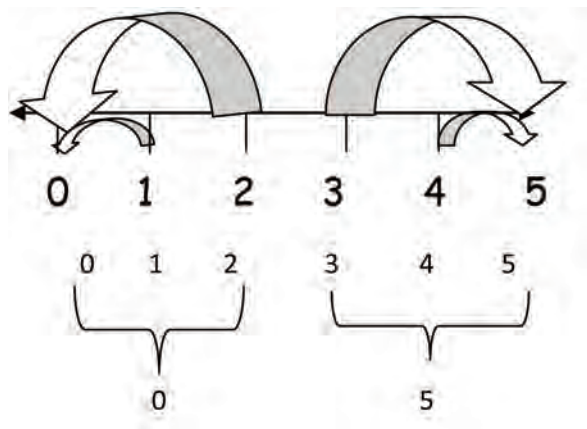

As per above diagram, when the last digit of a number is 2 or less than 2, then the number is rounded off to the nearest zero but if the last digit is 3 or more, then the number is rounded off to the nearest 5

340 = 340 341 will be rounded off to 340 342 will be rounded off to 340 343 will be rounded off to 345 344 will be rounded off to 345 345 = 345

Similar diagrams can be constructed to show learners the rules for rounding off to the nearest 10 and to the nearest 100.

PATTERNS, FUNCTIONS AND ALGEBRA

In this content area, it was observed that learners performed well in number patterns involving single variables but experienced challenges when they had to complete patterns by finding more than one correct value (variable) to complete tabulated information. Learners also demonstrated limited knowledge and skills in writing number sentences. Some of the observations made assessing this content area have been specified in the following sections.

a) Numeric Patterns

By Grade 5 learners are expected to demonstrate adequate knowledge and skills in investigating and extending numeric patterns using correct relationships and rules. The skill that was assessed in this section was that of identifying the rule and calculating the input and output values. It was observed that learners could not complete the missing input and output variables. In the example below learners were required to find values for the variables t and p . The rule that learners were expected to identify from the given complete values was to multiply the input number (x) by itself to get the output (y).

Skryf die waarde van p en t neer.

x	1	2	3	4	t
y	1	4	p	16	25

$p = 9$ en $t = 5$

In the example, the rule was to multiply the input number (x) by itself to get the output (y). It was observed that the expected rule was not applied. Instead it appeared that since p was below 3, p was equated to 3, and because 25 was below t, t was equated to 25. The correct value for p is 6 and the value for t is 5.

Remediation

Few guides can be given on how number patterns that relate to the input and output variables can best be taught. Allow learners to come up with their own patterns, analyse them and see which patterns have a general rule that applies to all output values when input values are given and which do not have such a rule. Once the principle has been understood, unknown number values can be introduced in the patterns either as inputs or as outputs to consolidate the learners' understanding.

Teaching of flow diagrams will enhance the understanding of the input and output values and might help with the understanding of number patterns presented in table form. The following example may be used to explain patterns in a table. Learners can look at the following pattern of figures and complete the table by writing the value of the alphabet:-



Number of Squares.	1	3	a	9	b
Number of match sticks.	4	12	20	c	76

a = _____ b = _____ c = _____

Learners need to or should analyse the pattern from the first figure to the last by counting the squares and then the match sticks. Then they derive the values for the variables based on the pattern. The pattern is checked and, if correct, a rule is derived. Thereafter by applying the rule, the correct input and output values can be calculated.

b) The writing of a number sentence.

By Grade 5 learners are expected to demonstrate appropriate knowledge and skills in writing an open-ended number sentence to consolidate understanding of additive properties of numbers. In general, when learners were asked to write a number sentence, they did so by writing only the visible numbers and ignored all the other relevant information that they were supposed to take into consideration. This might be because learners were not familiar with the mathematical terminology, as well as converting words into numeric symbols. In the example below learners were required to write a number sentence:-

Write an open number sentence for the following statement. Do not do the calculation.

Madiba Primary School planted 24 trees last year. Half of the trees didn't survive the winter and 2 more were damaged by the hail. How many were left?

24 - 2 = ? ~~X~~

The above example shows that only the visible numbers (24 and 2) were used to formulate a number sentence. The word "half" was not taken into account when formulating the number sentence. Consequently, the half of 24 that was supposed to be included in the equation was omitted. The process of translating words to numbers and signs seems to generally be a problem.

Remediation

The following remediation steps could be applied in introducing the concept of number sentences to learners:-

- Focus should be placed on the correct use of mathematical terminology, especially words like half, more and less;
- Learners should be exposed to techniques of dealing with word problems by firstly underlining the key words in the written sentence; and,
- Learners need to be taught how to translate the key words into correct mathematical operations (i.e. addition, subtraction, multiplication and division)

For Example:

There are 10 children in a the class and 20 more joined them. Half of them are boys. How many learners are boys?

$$(10 + 20) \div 2$$

Learners need to know that “more” means addition, hence the “20” is added to the original 10. They must also understand that half means dividing by 2, hence the total of 10 + 20 must be divided by 2.

4.2.2.3 SPACE AND SHAPE

In this content area, it was observed that learners performed well in locating the position of objects, drawings of symbols on a grid and indicating the type of view from a given picture. Specific weaknesses were experienced in describing and naming transformations and identifying 3-D objects.

a) Transformations

By Grade 5 learners are expected to demonstrate adequate knowledge and skills in describing transformations. The skills assessed were naming the transformation when the position of an object is changed. In general, a high percentage of learners could not identify the transformation of the shape. Learners displayed limited knowledge of how to perform two transformations to complete the transformation process. In the example below learners were required to name the types of transformations illustrated.

Which transformation(s) changed the position of the shape from A to B?

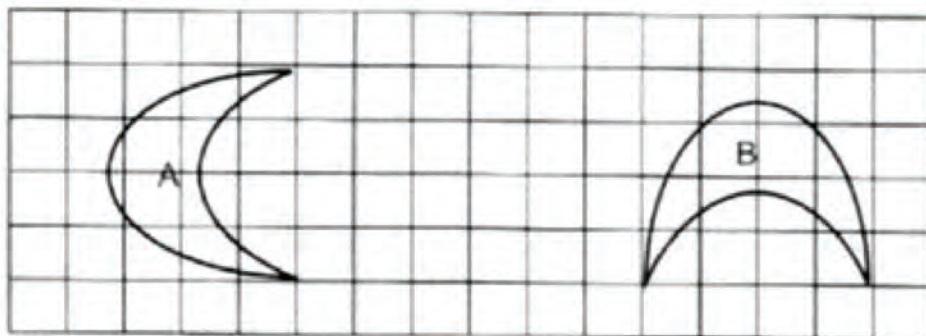

A. position ✓
 B. translation ✓
 (2) D ✓

In the example above the words position and transformation were used to name the transformation from shape A to B. However, two forms of transformation took place from shape A to B. Rotation and translation were the two transformations which were the correct answers. A good grasp of transformations is an important skill needed in the senior phase when drawing and rotating lines and shapes in a Cartesian plane.

Remediation

A variety of strategies should be used to enhance learners' knowledge on transformations. A more concrete hands-on approach can be taught by using cut-out polygons and pasting them in different forms of transformation. Learners should highlight the transformations by naming each of them. The words "reflection" (flipping along a line), "rotation" (spinning around a point) and "translation" (sliding) should be used regularly until learners are familiar with them. An illustration of each of the three transformations, viz. "translation", "reflection" and "rotation" has been shown below and could be used as one of the strategies to consolidate understanding of these important concepts.

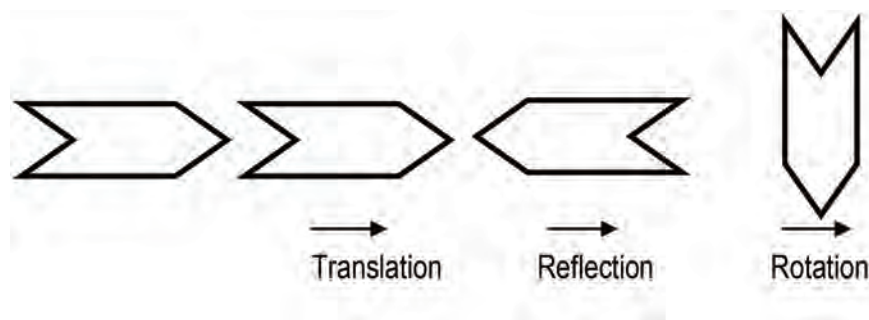

A practical demonstration could be done by making learners dance to a pre-recorded song in which the words "reflection", "rotation" and "translation" are used as each transformation is demonstrated in the dance. This could be a lesson enjoyed by all learners.

b) Properties of 3-D objects

By Grade 5, learners are expected to demonstrate good knowledge, skills and ability to distinguish, describe, sort and compare shapes. Learners were assessed in knowledge of naming 3-D objects, finding the number of faces of the affected object and naming the shapes of the faces. A high percentage of learners could not name a common 3-D object and displayed limited knowledge in finding the number of faces and naming the shapes. In the example below the learners were required to identify certain characteristics of a 3-D object.

Complete the table:

	Name of the object	Number of faces	Name the shape(s) of the faces
	Triangle Kraedel	3	Triangle

In the above example the naming of the 3-D object was incorrect. A high percentage of learners identified the object as a triangle, instead of a triangular prism.

Remediation

A simple remediation strategy is to use concrete objects from our daily lives to enhance the naming of 3-D objects. Recycled material can be used in which learners can unfold objects to view the various 2-D shapes that form the 3-D object. Objects can be analysed by counting the number of faces. By making models of 3-D objects learners can see how 2-D shapes are used to build 3-D objects. Use of toothpicks and jelly-tots will give the learners a clear view of building 2-D shapes, naming them and then forming a 3-D object. The example below illustrate how a rectangular prism is made up of 4 rectangles and 2 squares.

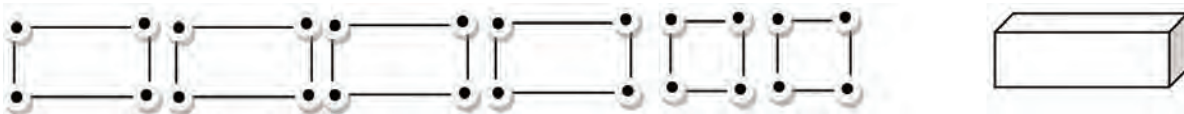

Rectangle + Rectangle + Rectangle + Rectangle + Square + Square = Cuboid/Rectangular prism

MEASUREMENT

In this content area, it was observed that learners performed well in calculating temperature. Specific weaknesses were experienced in calculating time intervals, perimeter, length and converting units of mass involving grams (g) and kilograms (kg).

a) Perimeter

By the end of Grade 4, learners are expected to demonstrate relevant knowledge and skills in measuring perimeter using rulers or measuring tapes and record the measurements in correct units. In Grade 5 learners practise and consolidate this skill based on what they have learnt in Grade 4. A common error was that learners showed an inability to identify that opposite sides of a rectangle have the same measurement. In the example below learners were required to calculate the perimeter of a soccer field in meters.

Calculate the perimeter of a rectangular soccer field with the measurements as indicated in the diagram.

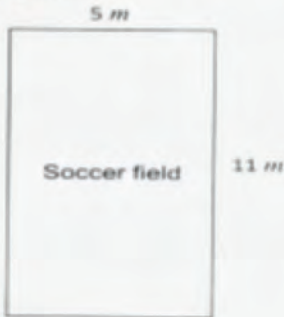

The diagram shows a rectangle labeled "Soccer field". The top side is labeled "5 m" and the right side is labeled "11 m".

Handwritten work on lined paper shows the following calculation:

$$\begin{array}{r} 5 \text{ m} \\ + 11 \text{ m} \\ \hline 16 \text{ m} \end{array}$$

The calculation is marked with a large "X" and the number "2" in a circle, indicating it is incorrect.

As per example above, the given length and the breadth were added to get an answer of 16 m. The common error was that learners are not account for the other sides, i.e length and breadth, making it difficult to ascertain whether learners did not know the definition of perimeter or they were unaware that opposite sides of a rectangle are equal. Otherwise the expected answer was 32 m.

Remediation

A possible remediation to teach about perimeter is to use a hands-on approach. Learners should measure items that they use daily in the classroom and calculate the perimeter. Another example would be to draw various shapes on the floor of the classroom. Ask learners to walk around the shapes, record and count the number of steps taken. Alternatively, learners can be given shapes drawn on square paper and asked to count the number of blocks. By participating in this exercise, learners will strengthen their conceptual understanding of perimeter by practically measuring the lengths of all the sides of shapes. An illustrated example is given below.

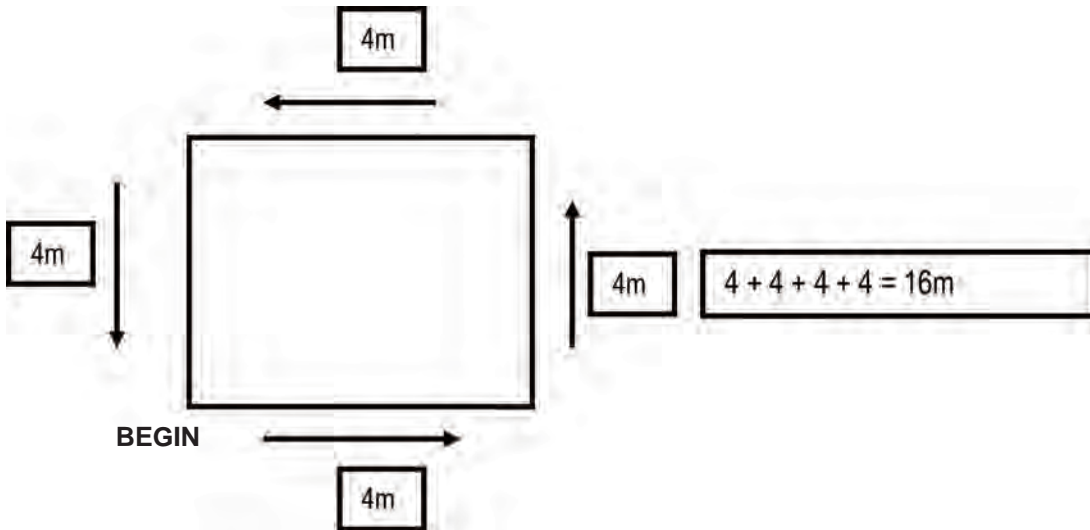

To calculate the perimeter of the above figure, learners need to be told to add the lengths of each side. In the above diagram each side is 4 metres. Learners should be shown where to begin their count. Each side must be counted. The perimeter works out to be $4+4+4+4=16m$. Similarly, learners can be given other diagrams with measurements of sides indicated and be asked to calculate the perimeter.

b) Conversions

By Grade 5, learners are expected to demonstrate acceptable knowledge and skills in understanding the relationship between metres and centimetres, and kilograms and grams. The skill assessed was to convert different units of length in a problem solving context. In general learners showed inability to answer questions involving the conversion between different units of measurement. In the example below learners were required to convert meters and centimetres to centimetres and then solve the problem.

Zahreen se lengte is 1 m 20 cm en Layyah se lengte is 63 cm. Hoeveel sentimeter moet Layyah groei om dieselfde lengte as Zahreen te wees?

By must be able to find out the size of the object
then by not writing α

The typical example above displayed learners' inability to interpret the problem. A high percentage of learners did not convert the 1 m and 20 cm to centimetres before subtracting the lengths.

Remediation

The purpose of this remediation is to provide guidance on minimising errors on conversions. Emphasis should be placed on practical demonstrations to show the relationship between different units of measurement.

The following steps could be used to remedy the problems encountered in conversions of units. When teaching conversions, emphasis must be placed on multiplication by a thousand since "kilo" means thousand and "milli" means one thousandth.

The following model may be used to teach conversion of units.

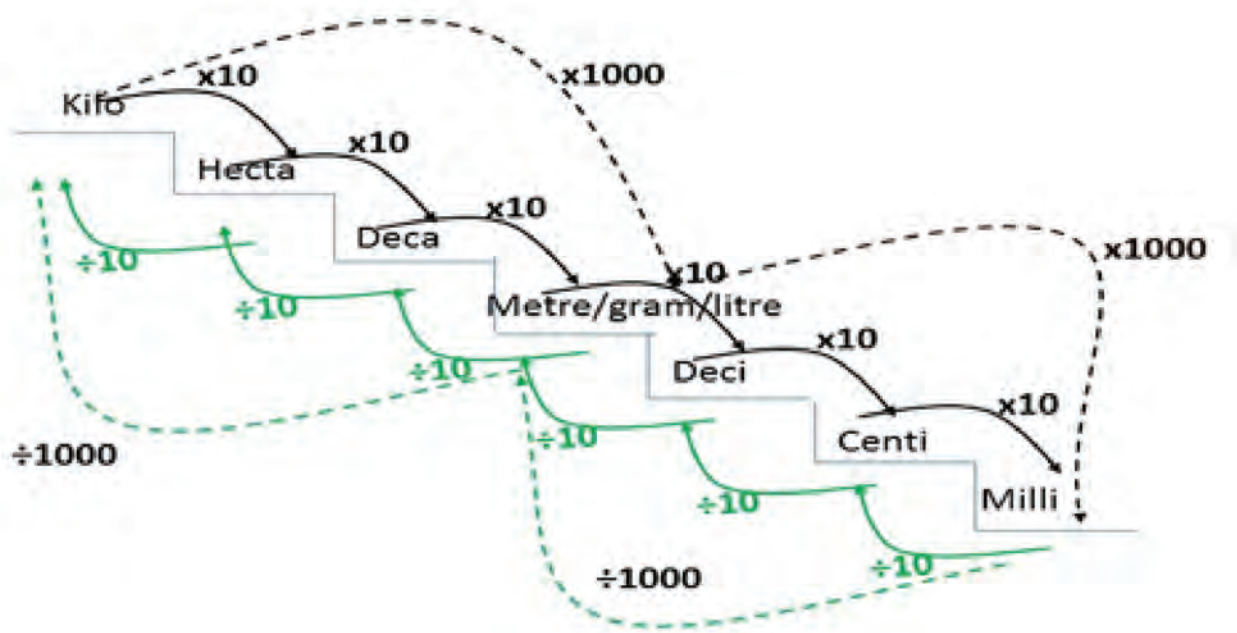

The model shows intervals of milli (grams/litres/metres) up to kilo(grams/litres/metres). The intervals range in units of tens e.g. converting from centi to milli, one would need to multiply by ten and from milli to centi one would need to divide by 10 thus 1 centimetre = 10 millimetre and 1 millimetre = 0,1 centimetre. Similarly, it is in noticeable the model that from kilo to the basic unit (metre/litre/gram) one needs to multiply by a thousand and vice versa thus 1 kilogram = 1000 grams and 1000 grams = 0,001kg.

The following mnemonic may be used for learners to remember the order of the units of measurement.

For English speaking learners (Kids Have Dreams Making Dad Chocolate Muffins)

For Afrikaans speaking learners (Klein Hettie Dans Met Die Chinese Meisie)

DATA HANDLING

In this content area, it was observed that learners performed well in interpreting the pie chart, calculating the median and identifying the mode. A variety of activities should be given to learners to consolidate understanding and improve learning performance in this area.

4.2.3 CONTENT AREAS, KNOWLEDGE AND SKILLS ASSESSED

The following content areas, knowledge and skills were assessed in the Grade 6 test.

a) Numbers, Operations & Relationships:

Assessed skills in this area included:-

- knowledge of place value(s) of numbers and expanded notations;
- knowledge of the technique of rounding off given numbers to the specified nearest number;
- ability to work with Operations (Addition, Subtraction, Multiplication and Division), solving money problems in given financial contexts; knowledge of and ability to work with properties of numbers;
- knowledge of and ability to do calculations based on ratio and rate; and,
- ability to solve problems involving common fractions, decimal fractions and percentages ability to identify and distinguish between multiples and factors of numbers.

b) Patterns, Functions & Algebra:

Knowledge and skills that learners had to demonstrate in this area included:- ability to write number sentences; demonstrating ability to solve problems that require knowledge of 'input and output values' and ability to identify Numeric and Geometric patterns and relationships.

c) Space & Shape:

Learners had to demonstrate knowledge of:- properties of 3-D objects; ability to locate position of objects in 2-D and 3-D space, skills in viewing and transformation of objects, recognising symmetry in shapes, and solving non-routine problems.

d) Measurement:

Learners had to demonstrate knowledge of and skills in calculating quantities such as mass, length, perimeter, temperature and volume of objects. They were also assessed on ability to calculate time and show how to do conversions in expressing measurement in different forms.

e) Data Handling:

Data handling skills that were assessed included ability to read and analyse pie-charts and calculate median and mode of a given set of numbers.

The performance of learners (average % marks) in the various content areas has been summarised in Figure 1.6.

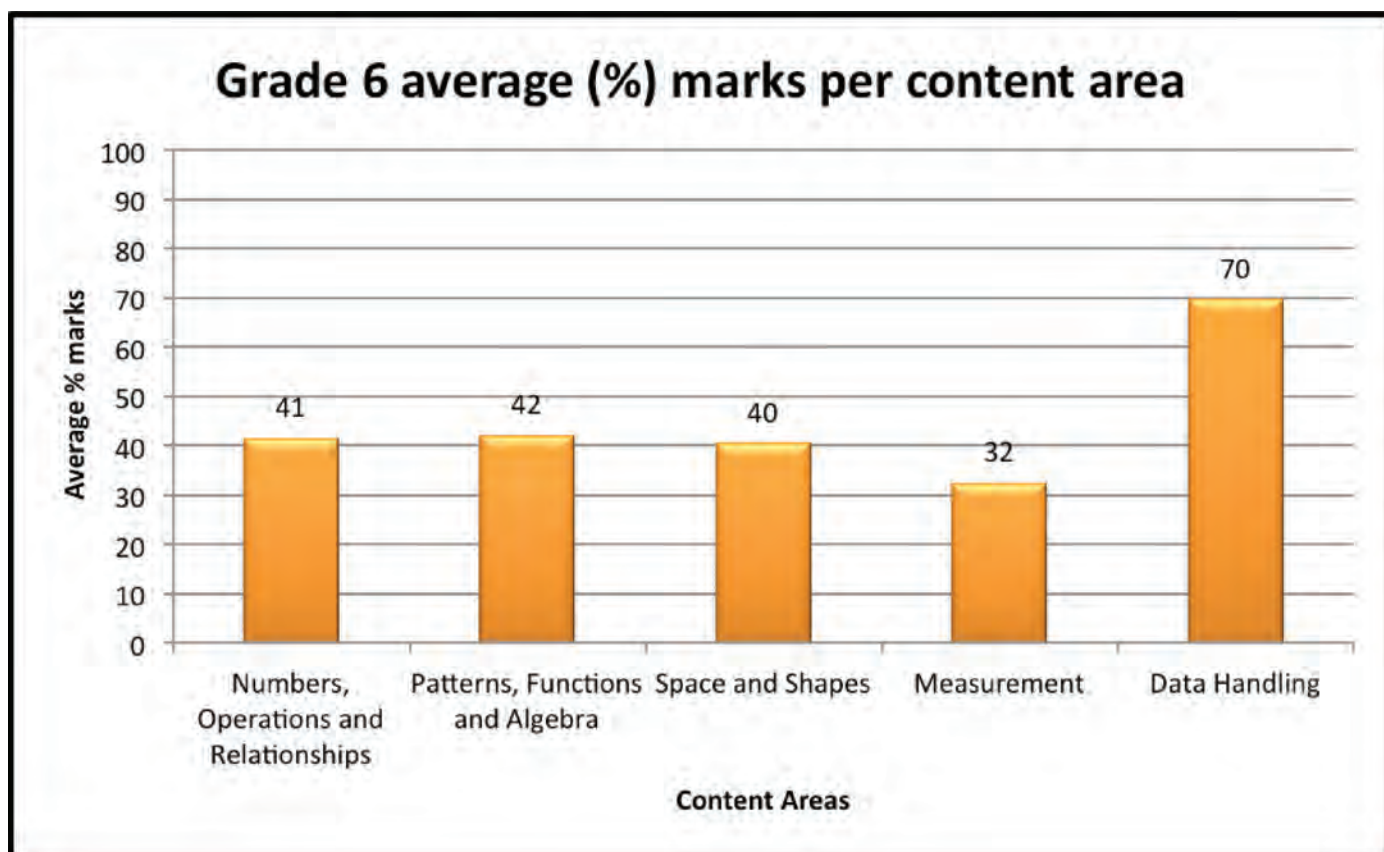

Figure 1.6: Learner performance in the various content areas

According to Figure 1.6, Grade 6 learners experienced the greatest difficulty in responding to questions on “Measurement”. The second area of marked difficulty as experienced by learners was “Space and Shape”. Learners found questions on “Data Handling” relatively easy to respond to, followed by “Patterns, Functions and Algebra”. There was a notable improvement in all content areas from the 2013 results.

NUMBERS, OPERATIONS AND RELATIONSHIPS

In this content area, it was observed that learners performed well in addition and subtraction of whole numbers, mixed numbers and decimal numbers. However, common errors and misconceptions were experienced in solving problems involving multiplication of a 4-digit by a 2-digit number, grouping and equal sharing with remainders, rate and ratio in financial contexts, long division, and examples have been illustrated on multiplication of a 4-digit by a 2-digit number and grouping and equal sharing with remainders.

a) Multiplication of 4-digit by 2-digit

In Grade 6, learners are expected to demonstrate adequate skills of multiplication of a 4-digit by a 3-digit number. The purpose in this area of Mathematics is to assess learner’s ability to use a suitable method of multiplication (e.g. vertical-column method, distributive property or any other correct alternative method). The example below shows a common error that was made using the vertical-column method of multiplication. A high percentage of learners could not multiply a 4-digit by a 2-digit number, which is lower than the number range prescribed for Grade 6 learners.

3 107 x 35

In the above example, the steps used in the method were incorrectly used and incorrect multiplication in the units and tens column was done. The multiplication by 5 and by 30 was incorrect, due to mistakes made by the learners in the multiplication steps, resulting in an answer of 121 065. However, the learners added correctly. Multiplication of a 4-digit by 2-digit number is an expectation of Grade 5, therefore it is important for learners to correctly apply the required multiplication skills otherwise they will not be able to solve 4-digit by 3-digit numbers.

Remediation

The purpose of this remediation strategy is to improve learners' ability to solve multiplication problems, by suggesting an alternative method of multiplying a 4-digit by a 2-digit number. An alternative approach is the "Napiers Bones" method. This method is used by teachers as a corrective measure to improve multiplication and to overcome shortcomings of the vertical-column method. The method is explained below.

Example of the "Napiers bones" method:

417 x 36

X	4	1	7
3	1/2	0/3	2/1
6	2/4	0/6	4/2
15	0	1	2

- Create a grid based on the size of the numbers you are multiplying e.g. if you are multiplying a 3-digit by 2-digit number you need a 4 x 4 grid;
- Learner writes the problem in the grid (e.g. 36 x 417);
- If the result of a calculation has two digits, the "tens" digit gets written above the diagonal line, and the "units" digit gets written below it;
- For instance, $6 \times 4 = 24$, so write the 2 above and the 4 below.
If the result of a calculation is only one digit, write a zero above the diagonal line;

- (1x6=6, so you write 0/6) 

- The tens digit is placed above the diagonal; the ones digit below the diagonal;
- When all squares have been completed, the student sums the numbers between each set of diagonals, and writes the sum at the bottom of the grid. NOTE: If the sum is greater than 10, regroup the ten to the next diagonal to the left;

X	4	1	7
3	1 /	0 /	2 /
6	2 /	0 /	4 /
15	0 /	1 /	2 /

- The student can now simply read the answer from left to right; and,
- The “Napiers bones” method can be applied to multiplication of a 4-digit by a 3-digit number and beyond.

b) Grouping and equal sharing with remainders

In terms of previous Grades, learners were expected to demonstrate adequate knowledge and skills in division of a 3-digit by a 1-digit with a remainder in context using various methods. It was evident that learners showed an improvement, from 2013, in understanding the required Mathematics operation in a word problem, formulating a number sentence and completing the division calculation. However, learners could not formulate a correct solution based on given information in the question. A high percentage of learners have not reached the appropriate level of drawing contextually correct conclusions that would make sense in “everyday” problem situations.

The purpose of the example below was to assess learners’ ability to interpret a word problem, write a number sentence from the word problem, do the calculation after identifying the operation to be used and finally formulate a correct solution.

If there are 8 sweets in a packet, how many packets can be filled with 947 sweets?

Handwritten student work for the division problem:

947 ÷ 8 = 118 rem 3

$$\begin{array}{r}
 118 \text{ rem } 3 \\
 8 \overline{) 947} \\
 \underline{8 } \\
 14 \\
 \underline{16} \\
 27 \\
 \underline{24} \\
 3
 \end{array}$$

118 rem 3 packets can be filled

It was observed that the correct solution of 118 full packets filled from a total of 947 sweets could not be formulated. Instead they indicated 118 remainder 3 packets can be filled. They did not take into consideration that only 8 sweets can be filled in a packet and there cannot be a remainder. In this type of examples learners must leave out the remainder since it leads to an incorrect solution.

Remediation

The purpose of this remediation is to provide a step by step guide on assisting learners in formulating correct solutions when working with a division with remainders. Particular attention should be on formulating correct solutions, taking into consideration the context of the question.

The following suggested steps can be used when teaching word problems.

Step 1: Read and understand the problem. Underlining key words.

Example: During a school trip 815 learners were transported in busses. How many busses were used to transport all the learners if each bus could transport a maximum of 65 learners?

Step 2: Make up a number sentence with the correct operation

$815 \div 65 =$ correct operation identified was division

Step 3: Calculate

$815 \div 65 = 12$ remainder 35

Step 4: Check the answer by reading step 1 and step 2 again to ensure that the answer responds to the question appropriately.

$12 \times 65 + 35 = 815$

Step 5: Statement/ deduction (check if it makes sense in terms of the question asked)

13 busses were used to transport all the learners

Learners should be made aware of different contexts. In this case an additional bus was used for the “remainder” of 5 learners, hence 13 busses were used. However in the context of the prior example relating to 8 sweets and how many packets can be filled with 947, the “remainder” of 3 sweets was not included in the deduction since it was required to say how many bags of sweets were filled.

PATTERNS, FUNCTIONS AND ALGEBRA

In this content area it was observed that learners performed relatively well in determining input values, output values and rules for patterns and relationships using flow diagram. However, common errors and misconceptions were experienced in investigating and extending numeric patterns looking for rules of patterns involving a constant and solving problems involving non-routine patterns.

a) Input values, output values and rules for the patterns and relationships using tables

By Grade 6, learners are expected to demonstrate knowledge and skills in determining the input and output values in a table. A key skill required identifying the rule, and applying it correctly to generate the required input and output values. A high percentage of learners were unable to see the relationship between the input and output values given in a table.

Below is an example, where learners had to complete the required input and output values.

Look at the input and output numbers and complete the table.

Input	2	3	4	5	10	22
Output	5	8	11	14	20	44

In the above example, the first four terms and the tenth term are given in the input value row. The input values of 2, 3, 4 and 5 have output values of 5, 8, 11 and 14 respectively. When 10 is the input value, the output value had to be calculated and when 44 is the output value, the input value had to be calculated. When the learners could not find the pattern, some learners resorted to multiplying or dividing by 2, hence they wrote 20 as the output and 22 as the input.

Learners should look for the relationship between the INPUT and OUTPUT, using the trial and error method. Due to the constant increase of 3 in the output value showing repeated addition, which links to multiplication, hence 3 times the input and by inspection subtract 1 is derived.

The rule in this case is $y = 3x - 1$; in simple terms the rule is $3 \times \text{input} - 1$

Remediation

The remediation outline below provides guidelines, showing how to establish a pattern by identifying the relationship between the input and output values in tables. Learners should be encouraged to practise more examples of this nature, starting with simple ones before moving on to complex patterns.

Example

INPUT	6	10	15	18	20	23
OUTPUT	10	14	19			

What do you have to do to each INPUT number to get to the OUTPUT number below it?

$$6 + 4 = 10 \qquad 10 + 4 = 14 \qquad 15 + 4 = 19$$

You add 4 to each INPUT number to get the OUTPUT number.

The rule for this table is Add 4.

Use the rule to complete the table. Then write the rule.

INPUT	6	10	15	18	20	23
OUTPUT	10	14	19	22	24	27

b) Non-Routine problem solving

In the Intermediate Phase, learners are expected to demonstrate skills of solving non-routine problems. In non-routine problems, learners are required to apply mathematical skills from different topics to solve a problem that they would not usually have seen in their routine classroom activities. As in 2013, a high percentage of learners did not solve the non-routine problems correctly. Often, non-routine problems are linked to finding patterns which have earlier been identified as an area of weakness.

In the example below, learners were required to find a pattern in order to determine the value of A.

Wat is die waarde van A in die vierde figuur? $A = \frac{4 \times 6}{2} = 12$

In this example, the inability to apply correct reasoning to determine a rule for patterns and relationships in a non-routine problem solving question, was identified. This type of example may be regarded as a higher order question and it is a required skill for learners to master in CAPS. The pattern is as follows: $1 + 3 \times 2 = 8$; $2 + 4 \times 3 = 18$; $3 + 5 \times 4 = 32$, therefore $4 + 6 \times 5 = 50$.

Remediation

A possible remediation strategy at this level for learners is to use the inspection method to solve the above type of problem. Learners should be exposed to more questions with a high cognitive level, in order to develop their application and reasoning skills.

Learners should be taught how to see the relationship between the numbers in each pattern model.

Simpler examples as shown below should be given to learners as practice activities with varying levels of difficulty in order to develop the learners' problem-solving skills. Below is an example of a non-routine problem that is cognitively less demanding than the one illustrated above.

The pattern is as follows: $2 + 3 + 6 + 4 = 15$, hence the solution is $5 + 7 + 4 + 1 = 17$

SPACE AND SHAPE

In this content area it was observed that learners performed satisfactory in identifying types of angles. However, common errors and misconceptions were experienced in symmetry, viewing of objects, 2-D shapes and 3-D objects.

a) Similarities and differences between rectangles and parallelograms

Learners in Grade 6 are expected to demonstrate knowledge and skills in distinguishing the properties of regular polygons such as rectangles and squares. Knowledge of these properties is a basic requirement before learners are exposed to other 4-sided figures (quadrilaterals) such as a rhombus and a parallelogram.

In the example below learners were required to complete the sentences using the properties of a rectangle and a parallelogram.

Study the parallelogram and rectangle and complete the sentences below.



The Opposite sides of a rectangle and parallelogram are equal in length.

The parallelogram and rectangle each has Two pairs of parallel sides.

In this example it was observed that the common error was the learners' inability to display correct knowledge of the properties of a rectangle and a parallelogram. The skill required was to identify the similarities and differences between the two quadrilaterals. The properties of rectangles and parallelograms are part of a broader knowledge and understanding of quadrilaterals. Learners are expected to know and understand the concept of a quadrilateral and how the properties of all special types are similar and different.

Remediation

The purpose of this remediation is to teach learners how to identify the properties of all quadrilaterals prescribed for Grade 6 by identifying similarities and differences between them.

Quadrilaterals

Quadrilateral just means "four sides"

(quad means four, lateral means side).

Any four-sided shape is a Quadrilateral.

But the sides have to be straight, and it has to be 2-dimensional.

Properties

- Four sides (edges)
- Four vertices (corners)
- The interior angles add up to 360 degrees:

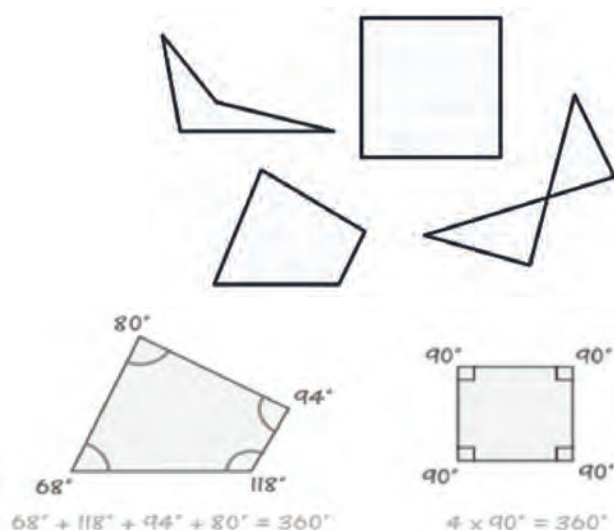

Types of Quadrilaterals

There are special types of quadrilateral:

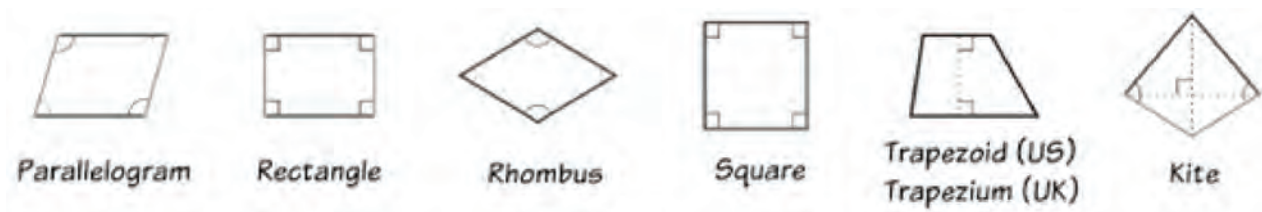

The Parallelogram

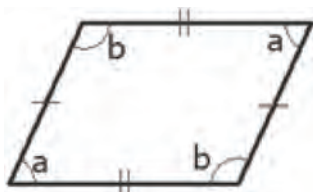

A parallelogram has opposite sides parallel and equal in length. Also opposite angles are equal (angles "a" are the same, and angles "b" are the same).

NOTE: Squares, rectangles and rhombuses are all parallelograms. Thus, they all have opposite sides parallel and equal in length, as well as opposite angles equal.

The Rectangle

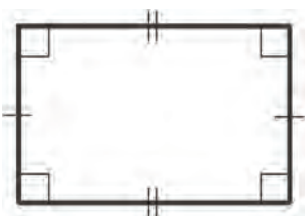

A rectangle is a four-sided shape which makes it a quadrilateral. It has all the properties of a parallelogram but all four angles in a rectangle are 90° .

Teaching strategies to reinforce the properties can include the following:

- Use concrete material to demonstrate the properties and differences of a rectangle and parallelogram; and,
- Use discovery method to investigate the properties by practically measuring the sides, angles and parallel sides.

b) 2-D Shapes

Learners build on their previous knowledge of their understanding of quadrilaterals and identifying regular and irregular polygons. At the Grade 6 level learners are expected to describe, sort and compare 2-D shapes in terms of the number of sides, length of sides, as well as the sizes of the angles. Knowledge of 2-D shapes is a requirement for solving problems on 3-D objects. It was observed that learners had difficulty in identifying 2-D shapes when it was drawn within a larger polygon.

In the example below, learners were expected to identify all the different 2-D shapes in a 8 sided polygon (octagon). Name the THREE different 2-D shapes in the diagram?



~~Length~~ Square ✓
~~Height~~ rectangle ✓
~~Weight~~ Triangles ✓

In the above example, the requirement was to identify a trapezium, a rectangle, a hexagon and an octagon, as the three possible different 2-D shapes. A high percentage of learners wrote squares and triangles as responses. Learners were not able to identify 2-D shapes which included more than three and four sides. Hence, they left out the trapezium, hexagon and octagon as answers. This knowledge gap is more apparent when learners have to identify these shapes within a composite diagram.

Remediation

The purpose of this remediation is to outline strategies used to expose learners to more examples in identifying the individual shapes contained in a composite diagram.

Example of a practice question:

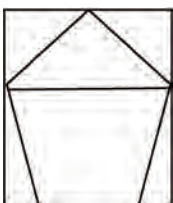

Teaching strategies to help learners consolidate the understanding of 2-D shapes are as follows:

- Use of practical concrete models and pictures to illustrate the basic 2-D shapes;
- Identifying 2-D shapes in the learners environment and in nature;
- Classifying shapes according to their properties; and,
- Practice activities to develop learners' insight into identifying shapes

MEASUREMENT



In this content area, it was observed that learners performed well in the practical reading of a kilogram scale. However, common errors in this content area included converting between units and time zones.

a) Reading time zones

In Grade 6, learners are expected to be able to read, tell and write time in 12-hour and 24-hour formats on both analogue and digital instruments. Learners are also expected to calculate time differences between different places in the world. In this grade, these types of problems are presented as word problems, which in the Intermediate phase present itself as an area of weakness.

In the example below, learners were required to calculate the time differences between two cities in different time zones.

Study the clock faces showing the time in Rome and Tokyo.
Rome and Tokyo are in different time zones.

	
Rome Time in the morning (a.m.)	Tokyo Time in afternoon (p.m.)

Calculate the time difference between Rome and Tokyo.
3 hours ✓

If it is 17:00 in Tokyo, what time will it be in Rome?
3 hours 20 hours ✓

It was observed in the example above that reading the time given on the analogue clock was incorrect. As a result, learners were unable to calculate the time difference between two cities in different time zones. In the example above, learners had to read the analogue times of the two cities correctly and then work out the time difference. Learners then had to use this information to calculate the time in Rome, in relation to the time given in Tokyo. A percentage of learners did not show any written mathematical calculation and resorted to counting the time interval from the displayed clocks. The correct answer of a 9 hour time difference between Rome and Tokyo was not worked out by subtracting the two time intervals, resulting in a high percentage of many learners guessing or incorrectly reading the time displayed.

Remediation

In order to remediate this area in Mathematics, learners should be exposed to reading time on an analogue clock, clearly indicating whether it is a.m or p.m time. Learners should be given more practice on calculating time differences between cities in different time zones.

At Grade 6 level, learners should use subtraction of time to calculate the time differences correctly.

8 : 15 pm	17 : 00 hrs
<u>-11 : 15 am</u>	<u>- 09 : 15 hrs</u>
<u>9 : 00 hrs</u>	<u>08 : 00 hrs</u>

The following are possible strategies which could be used to further assist learners to consolidate the understanding of reading time on an analogue clock and using time zones:

- The teacher may practically demonstrate reading time using an analogue clock;
- Practical activities must be given to allow learners to practice reading time in context (e.g. break time, supper time, etc.);
- Time zone maps may be used in order to explain the time differences between different cities; and,
- Practice activities may be given using an analogue clock to calculate the differences in time zones between the cities.

b) Convert kilograms to grams

Learners at Grade 6 level are expected to be able to convert between grams and kilograms. An important skill is for learners to work with conversions that include fraction and decimal form. The fractions and decimals that involve mass are used in everyday contexts. A specific problem identified in this area of Mathematics was that learners could not do the required conversions involving units of mass.

In the example below, learners were required to read the mass on the electronic scale and then convert the given mass from kilograms to grams.

Use the kilogram scale below to answer the questions.



What is the mass indicated on the scale? 56.8 kg ✓
 Convert the above mass to grams. 5680g ✓

It was observed that the reading of the measurement from the scale was correctly done. However the common error encountered was the learners inability to convert 56,8 kilograms to grams. A high percentage of learners converted incorrectly and gave the answer of 5 680g instead of the 56 800g. This points to learners not knowing the conversion scale of multiplying by 100 to change kg to g.

Similar conversions like the one presented in the above problem, are also required in converting litres to kilolitres, and metres to kilometres.

Remediation

As suggested in the remediation of this topic in Grade 5, the following steps could be used to remedy the problems encountered in conversions of units. When teaching conversions, emphasis must be placed on multiplication by a thousand since "kilo" means thousand. "milli" means one thousandth

The following model may be used to teach conversion of units.

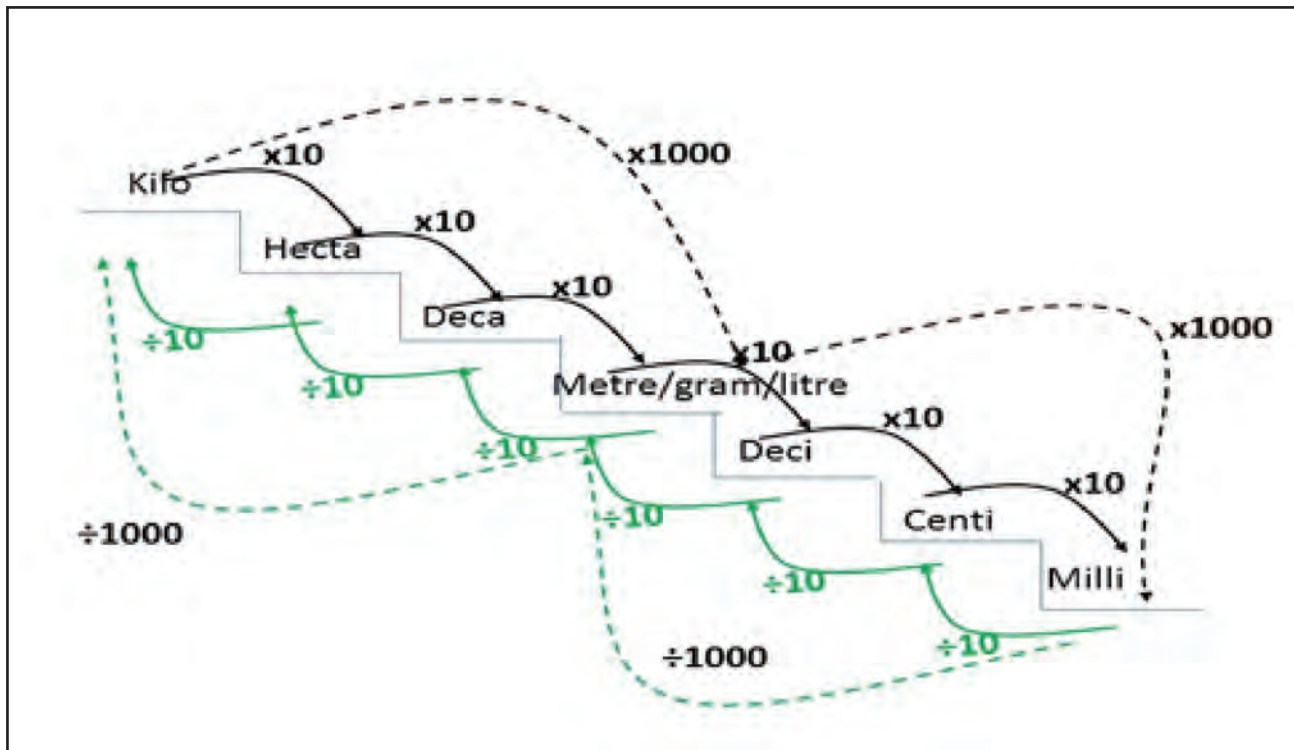

The model shows intervals of milli (grams/litres/metres) up to kilo(grams/litres/metres). The intervals range in units of tens e.g. converting from centi to milli one would need to multiply by ten and from milli to centi one would have to divide by 10 thus 1 centimetre = 10 millimetre and 1 millimetre = 0,1 centimetre. Similarly, the model shows that from kilo to the basic unit (metre/litre/gram) one has to multiply by a thousand and vice versa thus, 1 kilogram = 1000 grams and 1000 grams = 0,001kg.

The following mnemonic may be used for learners to remember the order of the units of measurement.

For English speaking learners (Kids Have Dreams Making Dad Chocolate Muffins)

For Afrikaans speaking learners (Klein Hettie Dans Met Die Chinese Meisie)

DATA HANDLING

In this content area, it was observed that learners performed well in data handling topics. Therefore, there are no areas of weakness to report on.

5. SENIOR PHASE (GRADE 9)

5.1 SUMMARY OF KEY FINDINGS

The key findings from the analysis have been summarised in two formats, firstly, in a histogram that shows how learner scores in each grade were distributed and the emerging patterns of score distribution across the grades and, secondly, in a tabular form that shows the areas of strength and weakness displayed by learners in each grade.

Overall performance of the sampled learners was at the “Not achieved” level (average of 10%). The distribution of learner percentage scores is shown in the histogram.

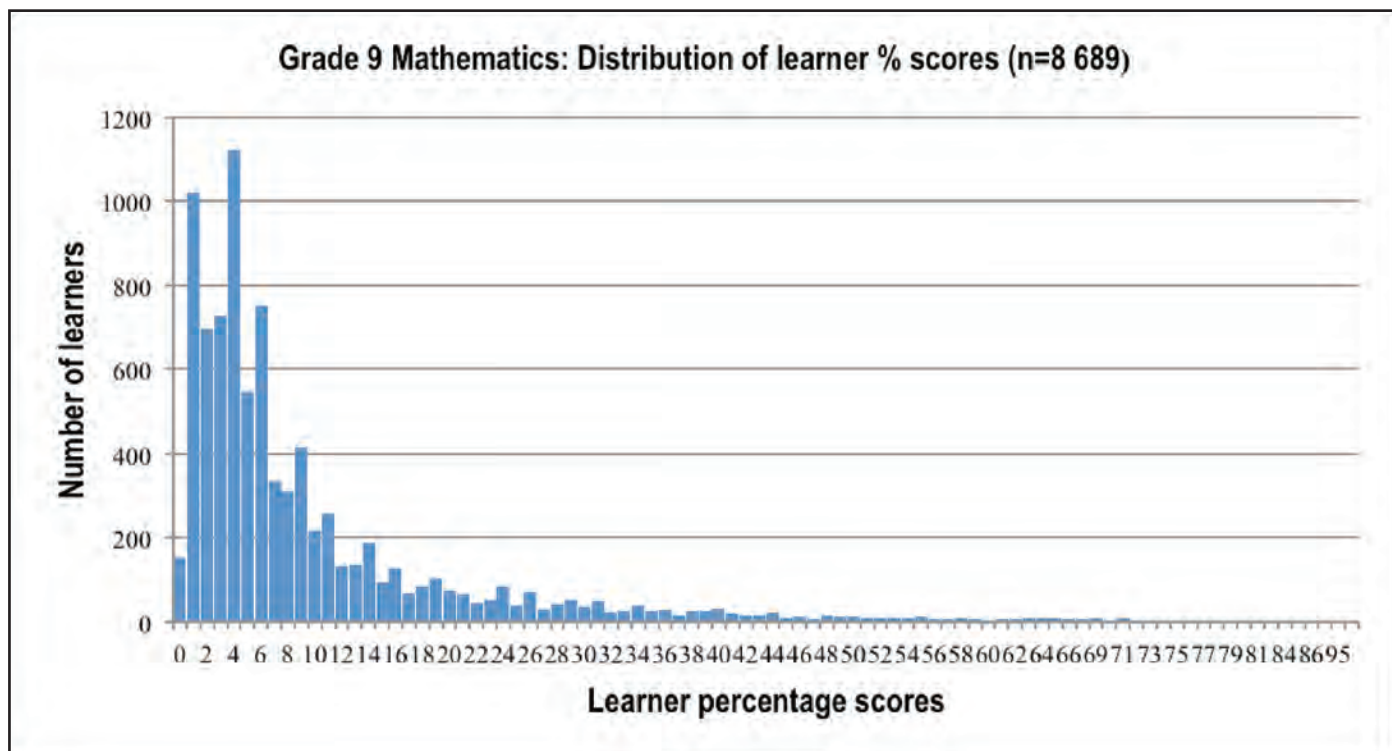

Figure 2.1: Grade 9 Mathematics: Distribution of learner % scores (n=8 689)

The learner scores in Grade 9 Mathematics ranged from 0% to 99% and the modal score (the score most frequently attained by learners) was 4%.

Overall, it can be observed that the distribution of learner scores in mathematics progressively shifts towards the lower end of the scale. All interventions must seek to correct this pattern.

The specific areas of strength and weakness displayed by Grade 9 learners have been summarised in Table 2.1.

Table 2.1: Summary of learner strengths and weaknesses in Grade 9 mathematics

AREAS OF WEAKNESS	AREAS OF STRENGTH
<p>Learner responses showed weaknesses in the following areas:</p> <ul style="list-style-type: none"> • Circumference and area of a circle; • Perimeter and area of a trapezium; • Congruency and similarity deductions; • Angles opposite equal sides of a triangle; • Lowest Common Multiple; • Square root and Cube root; • Direct and indirect proportion; • Terminology and definitions in geometry; • Factorisation; • Multiplication of fractions; • Determination of the gradient and the equation of a straight line; • Squaring of binomials; • Products of binomials; • Quadratic equations; • Equations involving fractions; • Determination of the general term; • Determining the coordinates of a point; • Addition and subtraction of fractions; • Percentages; • Angle relationships in parallel lines; • Exponents; and, • Theorem of Pythagoras. 	<p>Questions on the following areas were reasonably well answered:</p> <ul style="list-style-type: none"> • Writing out in scientific notation; • Finding the ratio of a given quantity; and, • Completing a number sequence.

From the above table, it is observed that there are a number of areas where learners require urgent support and remediation. As was the case in 2013, the learners found topics on Geometry difficult to answer. There were only a few areas where questions were answered well.

5.2 DETAILED DIAGNOSTIC ANALYSIS

Specific skills that were assessed, a detailed analysis, the findings, examples of learner responses, possible explanations for observed performance and recommended remediation interventions per grade have been presented in this section. A detailed analysis of the weaknesses, with examples of typical learner responses, has been presented in this section. For each identified weakness, possible explanations are offered and recommendations are made on possible remediation options.

5.2.1 CONTENT AREAS, KNOWLEDGE AND SKILLS ASSESSED

The following content areas, knowledge and skills were assessed in the Grade 9 test.

a) Numbers, Operations & Relationships:

Assessed skills in this area included:- Knowledge of integers; and the ability to solve problems involving square roots, exponents, decimal fractions, scientific notation, percentages, ratio, direct and indirect proportion, simple and compound interest.

b) Patterns, Functions & Algebra:

Knowledge and skills that learners had to demonstrate in this area included:- ability to find number patterns; and solve algebraic expressions and equations.

c) Space & Shape:

Learners had to demonstrate knowledge of and skills in solving problems involving geometry of straight lines and geometry of 2-D shapes.

d) Measurement:

Learners had to demonstrate knowledge of and skills in applying the theorem of Pythagoras, and finding the perimeter and area of 2-D shapes.

The performance of learners (average % marks) in the various content areas has been summarised in Figure 2.2.

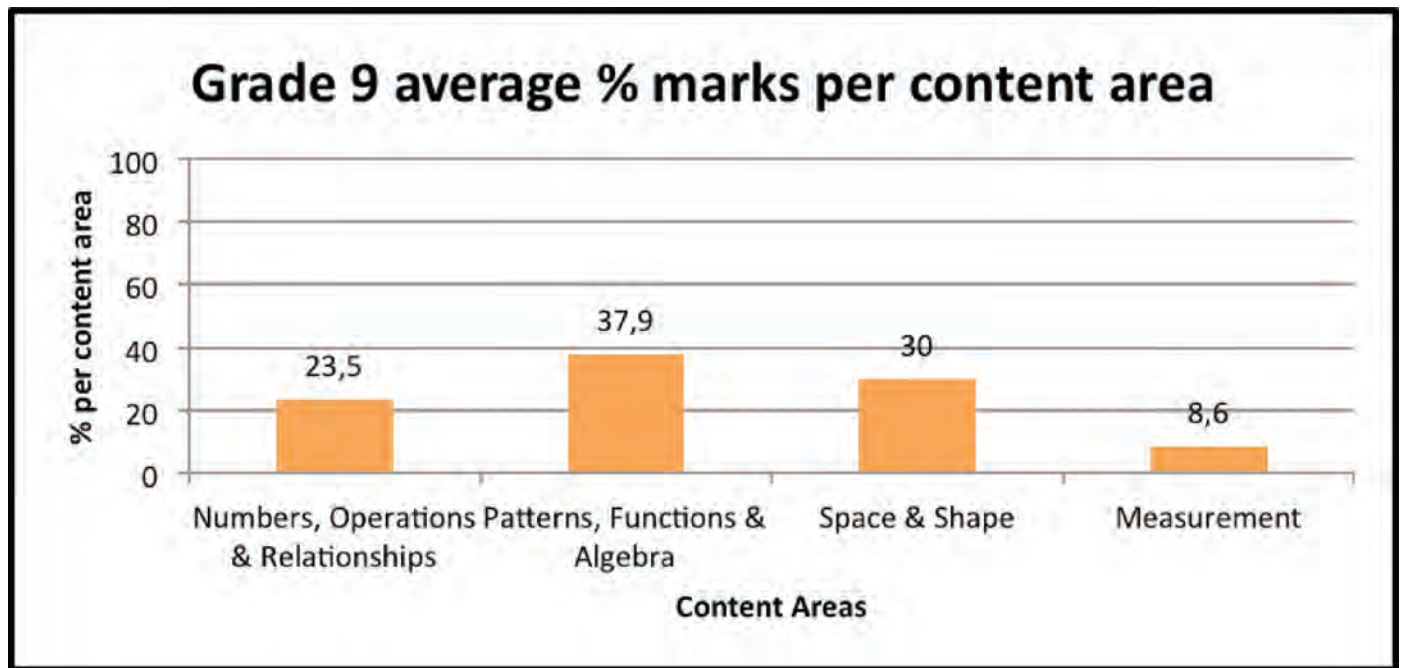

Figure 2.2: Grade 9 average % marks per content area

Figure 2.2 indicates that Grade 9 learners experienced the greatest difficulty in responding to questions on “Measurement”. The second area of marked difficulty as experienced by learners was “Numbers, Operations and Relationships”. Learners found questions in “Patterns, Functions and Algebra” relatively easier to respond to. This pattern of performance has not changed since the diagnostic analysis that was done in ANA 2013, suggesting that any remediation strategies implemented in Grade 9 need to be strengthened and perhaps extended across the phase.

NUMBERS, OPERATIONS AND RELATIONSHIPS

Specific learning weaknesses in the content area of “Numbers, Operations and Relationships” were in exponents, percentages, simple and compound interest. A detailed analysis of the weaknesses, with examples of typical learner responses, is presented in this section. For each identified weakness, possible explanations are provided and recommendations are made on possible remediation options.

a) Exponents

Exponents are introduced for the first time in Grade 7. In Grade 8, learners are expected to perform calculations involving the four basic operations with powers where the exponents are limited to natural numbers. In Grade 9, learners consolidate number knowledge and calculation techniques for exponents. In addition, laws of exponents are used to simplify exponential expressions and exponents are extended to negative numbers. However, it was evident that the Grade 9 learners had not grasped the basic knowledge required for calculations involving exponents. On exponents, learners were required to multiply and divide powers with natural numbers as bases. The examples below show three common errors, that were made by most learners. In all of them an incorrect application of exponential laws was applied.

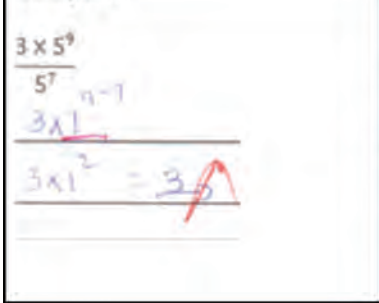
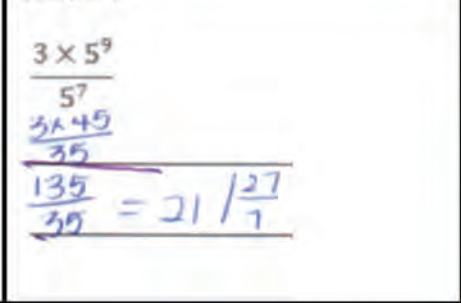
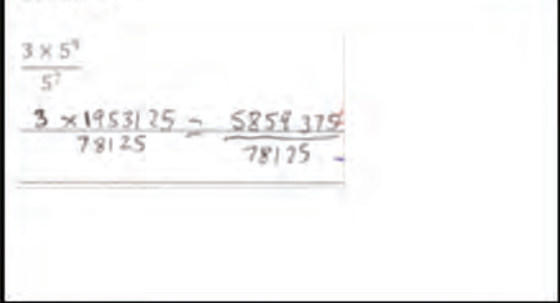
Example 1:	Example 2:	Example 3:
		

In Example 1, the learner demonstrated some understanding of the law of exponents by subtracting the exponents. The base was viewed as a whole number that is not related to the exponents 9 and 7 as illustrated. As such, the learner divided the two to obtain base 1. In Example 2 the learner simply multiplied the base of the power by the exponent. Most learners used a calculator as shown in Example 3 and did not follow the instruction of the question.

Remediation

The purpose of the remediation in this area is to assist learners to understand and apply exponential laws correctly. The following steps are suggested:

Revise / re-teach how to divide powers in which bases are variables.

For example:

$$i \quad \frac{x^5}{x^2} = x^{5-2} = x^3 \quad ii \quad \frac{x^3}{x^7} = x^{3-7} = x^{-4} = \frac{1}{x^4} \quad iii \quad \frac{2x^6}{x^5} = 2x^{6-5} = 2x$$

After learners have mastered working with bases which are variables, introduce division of powers where bases are natural numbers.

$$\text{For example: } \frac{2^5}{2^2} = 2^{5-2} = 2^3 = 8, \quad \frac{5 \cdot 3^7}{3^3} = 5 \cdot 3^{7-3} = 5 \cdot 3^4 = 5 \times 81 = 405$$

Note: A common error here is: $\frac{4^3}{2^3} = 2^{3-3} = 2^0 = 1$ or $\frac{4^3}{2^3} = \frac{12}{6} = 2$ instead of $\frac{(2^2)^3}{2^3} = \frac{2^6}{2^3} = 2^{6-3} = 2^3 = 8$

Learners should adhere to general instructions and specific question instructions such as using a calculator or not.

b) Percentages

In this content area, a high percentage of learners found it difficult to solve problems on percentages. The calculation of percentages is regarded as a basic mathematical skill at the Grade 9 level. Errors were found when learners were required to 'Decrease 240kg by 15%'. Below is an example of how learners applied their understanding of the word 'decrease' by percentages incorrectly and in the same way as with decreasing whole numbers. In addition, it is evident that learners lacked understanding of the 'percentage' concept.

Example:

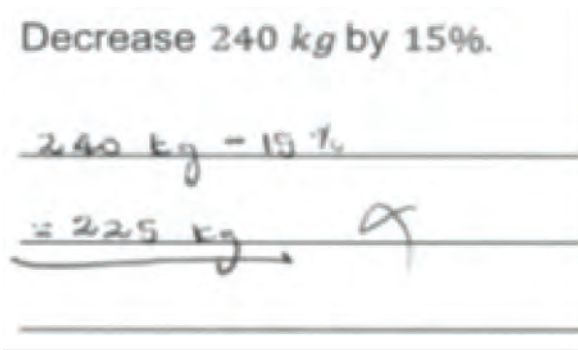

Decrease 240 kg by 15%.

$$\begin{array}{r} 240 \text{ kg} - 15\% \\ \hline = 225 \text{ kg} \end{array}$$

The image shows a student's handwritten work on a math problem. The problem is 'Decrease 240 kg by 15%.' The student has written '240 kg - 15%' on the first line, followed by a horizontal line. On the second line, they have written '= 225 kg' and underlined it. There is a small scribble to the right of the underline.

In the example, instead of calculating 15% of 240 kg before subtracting, the majority of learners subtracted 15 from 240. This resulted in an incorrect answer of 225 kg. Alternatively, learners could have worked out the solution as: 85% of 240kg = 225 kg. Responses as the one indicated above point to a typical lack of basic skills.

Remediation

The concept of percentage should be clarified for learners. A possible remediation in this area is for learners to interpret 'decrease' as an equivalent percentage form by subtracting the given decrease amount from 100% first and then only work out the percentage.

Example:

Decrease R150 by 10%.

First step: Interpretation: The decrease implies subtraction from 100%, therefore the required percentage to be worked out is $100\% - 10\% = 90\%$

Second step: Calculate the decreased amount = 90% of R150

$$\begin{aligned} &= \frac{9}{10} \times R150 \\ &= 9 \times R15 \\ &= R135 \end{aligned}$$

Learners should be given several examples of this type on practice worksheets to show that they understand both the skills of interpretation and calculation and not just calculation. The typical error of subtracting the decrease amount instead of working out the decreased percentage should be highlighted to learners.

PATTERNS, FUNCTIONS AND ALGEBRA

a) Simplifying algebraic expressions involving addition and subtraction

The overall learner performance in algebraic calculations, including algebraic fractions, indicates that the basic terminology, addition/subtraction and multiplication/division were not properly grasped. Learners were required to perform multiple operations to simplify algebraic fractions where denominators were multiples of each other.

Example:

The image shows a student's handwritten work on lined paper. At the top, the expression $\frac{x^2}{2} + \frac{2x^2}{3} - \frac{7x^2}{6}$ is written. Below it, the student has written $6\left(\frac{x^2}{2}\right) + 6\left(\frac{2x^2}{3}\right) - 6\left(\frac{7x^2}{6}\right)$. The next line shows $3(x^2) + 2(2x^2) - 1(7x^2)$. The final line shows $3x^2 + 4x^2 - 7x^2 = 0$. There are several red checkmarks and corrections throughout the work, indicating that the student's method of multiplying each term by 6 to clear denominators is incorrect.

In the example above learners incorrectly treated the expression as an equation and multiplied each term by 6 instead of introducing a common denominator.

Remediation

Consolidate knowledge and calculation techniques of common fractions before introducing the simplification of algebraic fractions. In addition, emphasize the use of equivalent forms for common fractions when performing multiple operations.

b) Simplifying algebraic expressions involving factorisation

Learners were required to simplify the algebraic fraction. The main skill that learners needed to utilise was factorisation of the numerator by taking out a common factor and by factorising the trinomial in the denominator. The majority of learners had some knowledge of dividing similar factors in the numerator and the denominator as in the example below; however, the procedure was incorrectly used. The skills assessed were factorisation of both numerator and denominator, and then simplifying.

Example:

$$\frac{x^2 - 4x}{x^2 - 2x - 8}$$
$$= \frac{2x}{-8}$$
$$= -\frac{1}{16}$$

In the example above, learners applied an incorrect mathematical procedure by dividing x^2 in the numerator by x^2 in the denominator. A similar incorrect mathematical procedure was applied by dividing $-4x$ by $-2x$. A possible cause is a lack of understanding of the difference between a term in an expression and the factors of an expression.

Remediation

Ensure that learners understand the difference between simplifying $\frac{x^2 - 4x}{x^2 - 2x - 8}$ and $\frac{(x^2)(-4x)}{(x^2)(-2x)(-8)}$. Clarify that in $\frac{x^2 - 4x}{x^2 - 2x - 8}$ the numerator has 2 terms and the denominator has 3 terms. Dividing by x^2 or $-2x$ is not allowed. However in $\frac{(x^2)(-4x)}{(x^2)(-2x)(-8)}$ dividing by the factors x^2 and/or $-2x$ is allowed because the numerator and the denominator each contain only one term.

The teaching of factorisation of expressions involving common factors, the difference of two squares and trinomials of the form $x^2 + bx + c$ should precede simplifying algebraic fractions.

c) Product of two binomials

In the examples below, learners were required to simplify an expression. The skills required were squaring a binomial and determining the product of two binomials. As such, these examples below show two common errors made by most learners.

Example 1:

$$2(x+2)^2 - (2x-1)(x+2)$$
$$= 2(x+2) \cdot 2(x+2) - 2(x-1)(x+2)$$
$$= 2x+4 + 2x+4 - 2x-1 + x^2+2$$
$$= 2x+2x+2x+x^2+4+4-1+2$$
$$= 6x^3 + x^2 + 8 + 1$$

Example 2:

$$2(x+2)^2 - (2x-1)(x+2)$$
$$= 2(2+2)^2 - (2-1)(2+2)$$
$$= 28$$

In Example 1 the learner applied the distributive property incorrectly and multiplied incorrectly by -1. In Example 2 the learner erroneously substituted the variable by 2.

Remediation

The correct application of the distributive property should be explained. Multiple calculations involving products of binomials should also be emphasized.

Emphasise the following facts to avoid misconceptions: $(x + y)^2 = x^2 + 2xy + y^2$ and not $x^2 + y^2$ and also that $(x + 2)(x - 3) = x^2 - x - 6$ and not $x^2 - 6$.

d) Factorisation

The question required learners to factorise the difference of two squares. As illustrated in the example below, the majority of learners did not seem to understand the concept of a common factor.

Example:

$$4x^2 - y^2$$
$$4(x-y)(x+y)$$

The common error was that most learners erroneously took out 4 as a common factor and did not realise that 4 is a square number.

Remediation

The factorisation of algebraic expressions is basic in Grade 9. Factorisation that involves common factors, the difference of two squares and trinomials of the form $x^2 + bx + c$ should be dealt with in detail.

Ensure that learners understand the difference between $4x^2 - y^2$ which equals $(2x + y)(2x - y)$ and $4x^2 - 4y^2$ which equals $4(x + y)(x - y)$.

e) Solving algebraic equations

The questions required learners to solve a quadratic equation, equations involving squaring binomials of the form $(x + 2)^2 + 3x - 2 = (x + 3)^2$ equations containing fractions and surds. In all the above mentioned questions it was observed that basic skills were lacking.

The examples below show three common errors made by most learners.

Example 1:	Example 2:	Example 3:
$(x-2)^2 + 3x - 2 = (x+3)^2$ $x^2 - 4 + 3x - 2 = x^2 + 9$ $3x + x^2 - 4 - 2 = x^2 + 9$ $3x^3 - 6 = x^2 + 9$ $3x^3 = 9x^2 \Rightarrow x = -1$	$\sqrt{\frac{1}{\sqrt{x}}} = 3$ $\frac{1}{\sqrt{x}} = 3$ $x = 3 + 1$ $x = 4$	$x^2 - 5x - 6 = 0$ $5x - x^2 = 0$ $4x - 6 = 0$ $2x = 0$

In Example 1, learners found it difficult to square binomials. They squared the first and the last term leaving out the middle term. Very few learners could solve for x in Example 2. In Example 3 learners could not solve the quadratic equation because they could not factorise the trinomial correctly and hence make the necessary deductions.

Remediation

Basic principles of squaring a binomial should be emphasised. To strengthen the conceptual understanding of 'squaring binomials', it should be emphasised that factorising trinomials is a reverse process of a product of two binomials or squaring a binomial,

e.g. $x^2 + 5x + 6 = (x + 2)(x + 3)$ because $(x + 2)(x + 3) = x^2 + 5x + 6$. In addition, if $x^2 + 5x + 6 = 0$ then $x + 2 = 0$ or $x + 3 = 0$. Therefore $x = -2$ or $x = -3$.

Similarly $x^2 + 6x + 9 = (x + 3)^2$ because $(x + 3)^2 = x^2 + 6x + 9$.

Also emphasise the fact that if $\sqrt{t} = 3$ then $t = 9$.

SPACE & SHAPE

Angle relationships, congruency and similarity

In Grade 8, learners are introduced to new terminology involving the relationships between pairs of angles formed by intersecting lines and parallel lines. This, together with the properties of the sides, interior and exterior angles of a triangle is of utmost importance and forms the foundation of the learners' Geometry knowledge and language.

In Grades 7 and 8, learners are expected to identify whether pairs of triangles are congruent or similar.

In Grade 9, the 4 axioms for congruency are introduced, namely; SSS , $S\angle S$, $\angle\angle S$ and $90^\circ HS$. In geometry learner performance was generally below standard. Although the majority of learners could identify pairs of congruent triangles they could not prove congruency between pairs of triangles as illustrated in Examples 1 and 2.

The skills assessed involved properties of angles and 2-D shapes, angle relationships involving parallel lines and interior angles of a triangle. They were also required to use the congruency axioms and make deductions. The other skills assessed involved proving either triangles congruent or similar and make required deductions. The examples below show that learners lacked geometry language, terminology and reasoning skills.

Example 1:

Statement	Reason
$\widehat{ABC} = \widehat{ACB}$	The sum of angles in a triangle is 180°
$\widehat{ACB} = \widehat{ACB}$	
$\widehat{ABC} = \widehat{ACB}$ (Corresponding)	

Example 2:



In $\triangle ABC$, $AB = AC$ and $\widehat{C} = x^\circ$. Determine the size of \widehat{A} in terms of x .

Statement	Reason
$\triangle ABC$	Are similar
AB	Are the sides
AC	Straight line

In Example 1 and Example 2, symbols indicating angles, degrees and/or triangles were left out or incorrectly written by most of the learners.

Remediation

The purpose of this remediation is to establish a firm foundation on which to build further knowledge and the application thereof.

- Revise the concepts dealt with in Grade 8 and reinforce the understanding of foundational skills and knowledge including relationships between angles formed by perpendicular lines, intersecting lines, and parallel lines cut by a transversal.
- Geometry concepts such as complementary, supplementary angles, adjacent complementary, adjacent supplementary, vertically opposite, corresponding, alternate, and co-interior angles should be clearly defined to enhance understanding before learners can apply them. For example \hat{A} and \hat{B} are complementary angles if $\hat{A} + \hat{B} = 90^\circ$.
- Make learners aware that the skills used in Algebra are also applicable in Geometry calculations, e.g. the mathematical procedures used to solve algebraic equations are also applicable when determining the size of an angle in Geometry as in Example 2.
- Revise the angle relationships using relevant diagrams. Ensure that learners know how to write a reason, using correct Geometry language, for each statement.

In the example below learners were required to select the triangle congruent to ΔPQR and to provide a reason.

Example 3:

Which triangle is congruent to ΔPQR ?

Statement	Reason
ΔFED	two sides are equal.

In Example 3 learners could identify the congruent triangle but the order of the vertices was incorrect.

Remediation

Use constructions to establish the minimum conditions for pairs of triangles to be congruent or similar.

Emphasise that to prove that triangles are congruent, information involving at least one pair of equal sides is essential. Furthermore, highlight that if triangles are equiangular they are similar. The 4 conditions of congruency should not be introduced simultaneously but rather one at a time. Emphasise that when naming a pair of congruent or similar triangles the corresponding vertices must be named and written in the correct order. Finally, emphasise the deductions that can be made when a pair of triangles is proved to be congruent or similar. For example in the figure below:

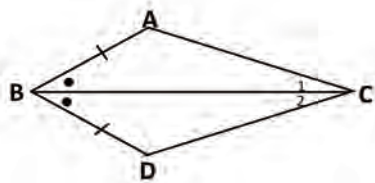

$$\triangle ABC \equiv \triangle DBC \text{ (s s)}$$

Then $AC = DC$ (Corresponding sides of congruent Δs)

$$\hat{A} = \hat{D} \text{ (Corresponding angles of congruent } \Delta s)$$

$$\hat{C}_1 = \hat{C}_2 \text{ (Corresponding angles of congruent } \Delta s)$$

In a case when $\triangle PTK \parallel \triangle MLN$ ($\angle \angle \angle$).

$$\frac{PT}{ML} = \frac{TK}{LN} = \frac{PK}{MN} \text{ (proportional sides of similar triangles)}$$

MEASUREMENT

Theorem of Pythagoras, perimeter and area

Learners are taught how to convert the units of length, area, volume and capacity in the lower grades. In Grade 7, learners are required to calculate perimeters and areas of squares, rectangles and triangles. In Grade 8, learners are required to calculate perimeters and areas of circles and in Grade 9 this is extended to trapeziums, parallelograms, kite and rhombi.

The example below shows typical errors made by learners. Most learners did not make a clear distinction between cm and cm^2 in all the measurement calculations. Many learners did not know the formulae of the area of a trapezium, the circumference of a circle and the area of a circle. Learners who attempted the question involving a circle lost marks by rounding off the answer of the radius or used π as 3.14 or $\frac{22}{7}$. The skills assessed were to determine the missing length of the side in a right-angled triangle, the perimeter and area of a trapezium and the area of a circle.

Example:

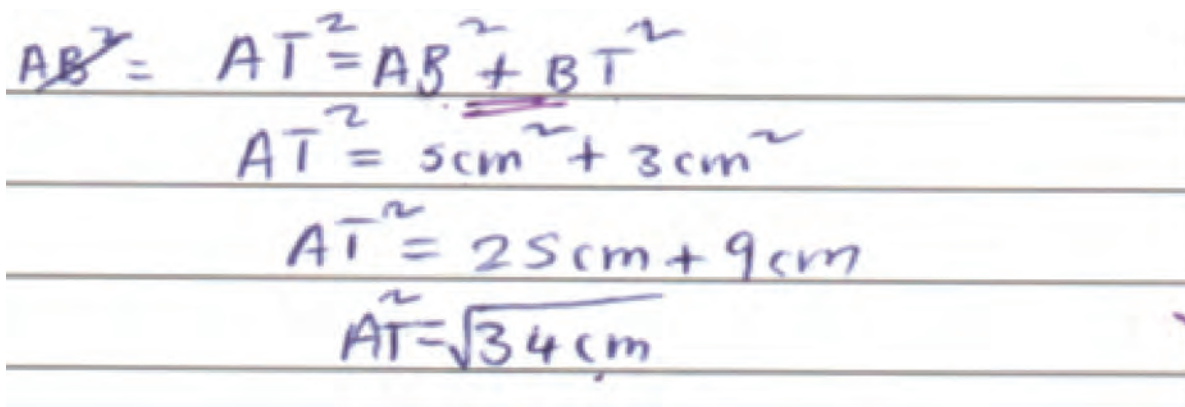
$$AB^2 = AT^2 = AB^2 + BT^2$$
$$AT^2 = 5\text{cm}^2 + 3\text{cm}^2$$
$$AT^2 = 25\text{cm} + 9\text{cm}$$
$$AT = \sqrt{34\text{cm}}$$

In the example above the learner did not know the relationship between the sides of a right-angled triangle. The common errors were: $AB^2 + BT^2$ or $AT = AB - BT$ instead of $AT^2 = AB^2 - BT^2$.

Remediation

The practical use of the Theorem of Pythagoras should be emphasised. More attention should be given to the meaning of the perimeters and areas of 2-D shapes. The structure of the formulae for determining the areas of the squares, rectangles, triangles, circles, parallelograms, trapeziums and rhombi should be dealt with in detail. This is essential pre-knowledge for calculating surface areas and volumes of 3-D prisms. Emphasize **cm** that is a unit of length, **cm²** is a unit of area and **cm³** is a unit of volume.

Also that $3\text{ cm} \times 5\text{ cm} = 15\text{ cm}^2$ but $3\text{ cm}^2 + 5\text{ cm}^2 = 8\text{ cm}^2$ and $\sqrt{16\text{ cm}^2} = 4\text{ cm}$.

Teachers should teach learners to always use the calculator value of π unless given as 3,14 or $\frac{22}{7}$.

**PART B:
FRAMEWORKS FOR IMPROVEMENT**



INTERMEDIATE PHASE (GRADES 4 – 6): MATHEMATICS

NUMBERS, OPERATIONS AND RELATIONSHIPS

Identified weaknesses	Responsibility				
	Remedial measures to improve classroom practice	DBE	Province	District	School
<p>Multiplication and Division of whole numbers:</p> <p>Lack of understanding of place value</p>	<ul style="list-style-type: none"> Conceptual understanding of place value should be enhanced to improve learner proficiency in calculations involving the four basic operations. The breaking-down technique and the column methods should be taught very effectively as they have a potential to strengthen the understanding of place value. 	<p>Ensure that all schools have copies of CAPS because it provides critical information on the scope and strategies for the teaching of place value and operations with whole numbers.</p>	<ul style="list-style-type: none"> Utilise the provincial Subject Committee meeting to explore additional strategies to teach place values and operations with whole numbers. Share the strategies with districts and schools. Monitor availability of CAPS and report shortages where identified. 	<p>Conduct workshops to address the critical skills of improving conceptual understanding of place value.</p> <p>Demonstrate to teachers how breaking-down technique can be used to teach place value</p>	<ul style="list-style-type: none"> Teach the following to enhance conceptual understanding of place value: <ul style="list-style-type: none"> - Ordering: comparing numbers with each other. - Position: understanding how the place of a digit in any number affects its value, e.g. in 324 the 4 is worth four ones/units while in 432 the 4 is worth four hundreds. - Amount: knowing what the digits represent. Introduce the breaking-down technique or the column method to enhance the understanding of place value. Use exercises from the workbooks and the guidance from the CAPS.

<p>Word problems: Learners were not able to:</p> <ul style="list-style-type: none"> • interpret word problems correctly; • use the given information appropriately; • translate language into mathematics language and write correct mathematical sentences; • respond to the question posed after correctly calculating the answer. 	<p>Strategies of answering word problems should be taught. These include:</p> <ul style="list-style-type: none"> • reading with understanding; • underlining the key words and information; • translating certain words into mathematics language; • identifying the appropriate mathematics operation; • constructing a mathematics sentence; and, • carrying out mathematical calculations to get the answer and respond to the question posed. 	<ul style="list-style-type: none"> • Print and distribute the teaching materials developed by the DBE-JICA project to support the teaching of word problems. • Strengthen the DBE workbooks during the annual review to ensure that word problems are comprehensively addressed. • Ensure that word problems are adequately addressed in the forthcoming Sasol-Inzalo workbooks. • Monitor the utilisation of DBE-JICA materials, DBE workbooks and Sasol-Inzalo workbooks. 	<ul style="list-style-type: none"> • Mediate the DBE-JICA materials with district officials. • Monitor the availability of DBE workbooks and DBE-JICA materials in districts and schools and report the shortages. • Print and distribute Sasol-Inzalo workbooks to all districts and schools. • Strengthen co-operative work with Language subject co-ordinators to acquire the skills such as reading with understanding, interpretation and comprehension. 	<ul style="list-style-type: none"> • Conduct a workshop on how to teach word problems. • Work collaboratively with Language subject advisors to acquire more skills such as reading with understanding, interpretation and comprehension. • Encourage teachers to develop their own activities on word problems. • Monitor utilisation of supplied materials. 	<ul style="list-style-type: none"> • Teach the following strategy of answering word problems: <ul style="list-style-type: none"> - reading with understanding; - underline key words and information; - translate certain words into mathematics language; - identify the appropriate mathematics operation; - constructing a mathematics sentence; and, - carry out mathematical calculations to get the answer and respond to the question posed. • Work collaboratively with language teachers to acquire more skills such as reading with understanding, interpretation and comprehension. • Use the DBE workbooks to give learners more practice work on word problems. • Encourage learners to develop their own word problems.
--	---	---	---	---	--

<p>Common fractions</p> <p>Learners were unable to recognise and interpret equivalent common fractions when represented in different diagram forms</p>	<ul style="list-style-type: none"> The teaching of fractions should start from using concrete objects to enhance conceptual development before proceeding to abstract manipulations of fractions. Equivalent forms of fractions should be taught, e.g. percentages, decimal fractions, common fractions, improper fractions. Correct strategies and conventions of addition, subtraction, multiplication and division should be used during teaching. 	<ul style="list-style-type: none"> Compile a list of appropriate resources needed to teach fractions. Distribute the list to provinces. 	<ul style="list-style-type: none"> Procure appropriate resources for the teaching of fractions. Distribute the resources to districts and schools. Ensure that each subject advisor has the same resource kit as schools. Mediate the resources with districts. Monitor utilisation of resources. 	<ul style="list-style-type: none"> Ensure that all schools have appropriate resources and know how to use them to develop conceptual understanding of fractions in the Intermediate Phase. In addition guide teachers on making own models for teaching fractions. Encourage teachers to use the workbooks and textbooks. Monitor the implementation of the 2014 ANA Improvement Plan. 	<ul style="list-style-type: none"> The following strategies are suggested to enhance conceptual understanding of fractions: <ul style="list-style-type: none"> - Start by utilising area/region models where learners can visualise part of a whole. - Then use length/ measurement model where learners can compare lengths, and - When learners show understanding of fractions in the context of area and measurement the set models can be introduced where a whole is a set of objects and subsets of the whole make up fractional parts. Encourage learners to develop own models to demonstrate the understanding of fractions. Identify possible misconceptions/errors and correct them immediately. Before introducing calculations involving fractions ensure that learners: <ul style="list-style-type: none"> - understand fraction concept; - are able to compare fractions and recognise equivalent fractions; - have developed fraction number sense; and - Understand the four basic operations on whole numbers.
--	--	---	--	--	--

INTERMEDIATE PHASE (GRADES 4 – 6): MATHEMATICS

PATTERNS, FUNCTIONS AND ALGEBRA

Identified weaknesses	Responsibility				
	Remedial measures to improve classroom practice	DBE	Province	District	School
<p>Extending patterns: Learners were unable to establish the relationship between the input and output values given in a table.</p>	<ul style="list-style-type: none"> Start by teaching geometric patterns and integrate with numeric patterns. Use geometric patterns to generate a number pattern and present the pattern in a tabular form to demonstrate the input and output values. Teach all the different types of patterns as presented in the CAPS. 	<ul style="list-style-type: none"> Ensure that adequate guidance and clarity are provided on numeric and geometric patterns in the DBE workbooks and Sasol-Inzalo materials. Ensure that Sasol-Inzalo workshop addresses the topic on numeric and geometric patterns adequately. Ensure that all schools have workbooks. Conduct monitoring to ensure effective curriculum implementation and coverage. 	<ul style="list-style-type: none"> Participate in the annual review of DBE workbooks and Sasol-Inzalo screening and ensure that the topic on numeric and geometric patterns is adequately addressed in terms of clarity. Ensure that Sasol-Inzalo workshop addresses the topic on numeric and geometric patterns adequately and provides guidance on the teaching of input and output values. Conduct monitoring to ensure availability of CAPS and workbooks in all schools and report shortages. 	<ul style="list-style-type: none"> Support teachers by conducting focused workshops. Conduct regular monitoring to ensure curriculum coverage. Provide onsite classroom support to teachers Conduct monitoring to ensure availability of CAPS and workbooks in all schools and report shortages. 	<ul style="list-style-type: none"> Start by teaching geometric patterns and then generate number patterns from geometric patterns. Allow the learners to: <ul style="list-style-type: none"> practically construct geometric patterns using concrete objects such as match sticks and later draw geometric shapes to represent a pattern; generate a number pattern from a geometric pattern and represent it in a table; generate their own patterns and describe them using own words; and, Teach the flow diagrams (input and output values) as another way to enhance the understanding of number patterns.

<p>Number sentences: Instead of translating a description given in words into a number sentence, learners wrote part of a number sentence and solved it.</p>	<ul style="list-style-type: none"> • A concept 'Number sentence' should be clearly defined to enhance understanding. • The teaching of number sentence should be done systematically by highlighting: <ul style="list-style-type: none"> - identification of the key concepts, - underlining the key concepts, - translating the underlined concepts into mathematical symbols. 	<ul style="list-style-type: none"> • Ensure that mathematics dictionaries form part of the supplementary LTSM and are quality-assured (screened) to ensure grade appropriateness and CAPS aligned. • Ensure that textbooks and workbooks address Number sentences adequately and clearly. 	<ul style="list-style-type: none"> • Supply dictionaries to all primary schools to enhance the understanding mathematics concepts such as perimeter. • Ensure that textbooks and workbooks address Number sentences adequately and clearly. 	<ul style="list-style-type: none"> • Develop teaching activities support teachers on content knowledge and pedagogy regarding Number sentences. • Emphasise that Number sentences provide foundational knowledge and skills required in Algebra in higher grades. 	<ul style="list-style-type: none"> • Provide clear definition of 'Number sentence'. • Teaching should enable learners to: <ul style="list-style-type: none"> - Identify the key concepts, - underline the key concepts, - translate the underlined concepts into mathematical symbols. • Start by teaching learners to represent single words mathematically, and then introduce simple sentences and later complex sentences. • Allow learners to develop their own descriptions and represent them in a number sentences.
--	---	---	---	---	---

Intermediate Phase (Grades 4 – 6): Mathematics

Space & Shape (Geometry)

Identified weaknesses	Responsibility			
	Remedial measures to improve classroom practice	DBE	Province	District
<p>Use concrete objects and relate them to the drawings of the 3D objects so that learners can observe the faces, edges and vertices.</p> <p>3D objects and 2D shapes should be taught in an integrated manner, however 3D objects should be introduced first because learners are already familiar with them.</p> <p>3-D Objects: Learners could not name the 3-D object; identify the number of faces and naming the shapes of the faces.</p> <p>2-D Shapes: Inability to name a given 2-D shape and classify it as regular or irregular shape.</p>	<ul style="list-style-type: none"> The teaching of 3D objects requires a resource-rich classroom environment, the national Mathematics Subject Committee will compile a list of all resources required to teach mathematics in primary schools and distribute to provinces, districts and schools for guidance. Each subject advisor should have a resource kit that they can use to support teachers. 	<p>Discuss with the subject committee members the innovative strategies of teaching the properties of 3D objects and how to make resources available to schools, e.g. collecting resources from learners' environment.</p>	<ul style="list-style-type: none"> Support teachers with innovative strategies to teach 3D objects by naming them and identifying the number of faces and naming the shapes of faces. Guide teachers on integrating the teaching of 3D objects and 2D shapes instead of teaching them in isolation. Provide on-site classroom support to teachers. 	<ul style="list-style-type: none"> Start with the teaching of 3D objects and then integrate with 2D shapes. Use concrete objects so that learners can: <ul style="list-style-type: none"> visualise by observing and then naming the objects; analyse by counting the number of faces, vertices and edges. sketch or draw the 3D objects; and, make models of the 3D objects. Practically show learners the relationship between the names of the 3D objects and the shapes of their faces, e.g. a triangular pyramid has a triangular base and a square-based pyramid has a square base. A square-based pyramid is, therefore, made of a square and triangular faces. Encourage learners to collect 3D objects from their home environment to ensure a resource-rich classroom.

Intermediate Phase (Grades 4 – 6): Mathematics

Measurement

Identified weaknesses	Remedial measures to improve classroom practice	Responsibility			
		DBE	Province	District	
<p>Conversions:</p> <p>Learners were required to convert meters to centimetres and express a quantity given in grams in kilograms and grams.</p>	<p>Practically demonstrate to learners how a centimetre and a meter relate using a measuring tape calibrated in centimetres and meters, and a kilogram and a gram using mass meters calibrated in kilograms and grams.</p>	<ul style="list-style-type: none"> • Compile a list of resources needed to teach conversions including measurement of time, volume, mass, length. • Distribute the list to provinces for procurement. • Strengthen monitoring and support. • Supply and monitor the utilisation of workbooks for more guidance on how to teach conversions. 	<ul style="list-style-type: none"> • Ensure that all schools and district officials have the relevant measuring instruments to teach conversions. • Strengthen monitoring and support for districts and schools. 	<ul style="list-style-type: none"> • Ensure that all schools have the necessary measuring instruments for practical demonstrations to the learners on how to convert from one unit to the other. • Support teachers with innovative strategies to teach conversions. • Provide on-site classroom support to teachers. 	<ul style="list-style-type: none"> • Conduct practical demonstrations to show the relationship between metres and centimetres, and grams and kilograms. • Create opportunities for learners to measure the same mass of, for example sugar, using two mass meters calibrated in grams and in kilograms let them draw conclusions.
<p>Perimeter:</p> <p>Lack of understanding of:</p> <ul style="list-style-type: none"> - the concept of perimeter; and - properties of 2-D shapes. 	<p>The properties of 2-D shapes should be taught before the concept of perimeter of 2-D is dealt with.</p>	<ul style="list-style-type: none"> • Ensure that mathematics dictionaries form part of the supplementary LTSM and are quality-assured (screened) to ensure grade appropriateness and CAPS aligned. 	<ul style="list-style-type: none"> • Supply dictionaries to all primary schools to enhance the understanding mathematics concepts such as perimeter. 	<ul style="list-style-type: none"> • Concepts such as perimeter should be clarified to teachers during workshops and subject committee meetings. • Ensure that teachers understand the importance of the properties 2-D shapes when teaching 'perimeter', e.g. if the sizes of only two sides of a rectangle are given, learners should use the fact that the opposite sides of a rectangle are equal to and be able to calculate perimeter. 	<ul style="list-style-type: none"> • Develop conceptual understanding by practically demonstrating the concept 'perimeter'. • Let learners use own language to define perimeter. • Emphasise that perimeter is NOT the 'outer line' enclosing a figure but a distance around the figure. • Emphasise the properties of 2-D shapes.

Senior Phase (Grades 9): Mathematics

Numbers, Operations and Relationships

Identified weaknesses	Responsibility				
	Remedial measures to improve classroom practice	DBE	Province	District	School
<p>Exponents: Learners lacked the basic knowledge required for calculations involving exponents.</p>	<p>Exponents are introduced for the first time in Grade 7 and in Grade 9 number knowledge and calculation techniques for exponents should be consolidated.</p>	<ul style="list-style-type: none"> Ensure that each teacher has a copy of Mathematics CAPS to as a guide on the extent to which exponents should be covered per grade in the Senior Phase. Ensure that each learner has a copy of the DBE workbook to practice activities focusing on exponents. 	<ul style="list-style-type: none"> Monitor the availability of CAPS and DBE workbooks and report shortages. Work with subject advisors to develop teaching and assessment exemplars to be used during workshops conducted by districts. 	<ul style="list-style-type: none"> Develop exemplars for teachers and conduct focused workshops on the teaching and assessment of exponents. Ensure that the scope of work prescribed for each grade in the CAPS focusing on exponents is adequately taught. 	<ul style="list-style-type: none"> Start by introducing division or multiplication of powers in which bases are variables. After learners have mastered working with bases which are variables, introduce powers where bases are natural numbers. Look out for common errors/misconceptions such as: such as: $\frac{4^3}{2^3} = 2^{3-3} = 2^0 = 1$ <p>Introduce the application of exponents to simplify expressions involving multiplication or division of monomials, binomials and trinomials by monomials.</p>

<p>Percentage:</p> <ul style="list-style-type: none"> - Lack of an understanding of the 'percentage' concept; and, - Word problem involving percentages. 	<ul style="list-style-type: none"> Percentage is an equivalent form of fraction i.e. a fraction with the denominator 100. A conceptual understanding of this special type of a fraction should be developed before it can be applied in different contexts. The teaching of English across the curriculum should be encouraged to mitigate the impact of language in the teaching of mathematics especially when dealing with word problems. 	<ul style="list-style-type: none"> Provide all provinces with the materials developed in partnership with JICA on strategies of teaching word problems. Provide the English Across Curriculum Framework to all provinces. 	<ul style="list-style-type: none"> Adapt the activities in the DBE-JICA materials to be appropriate for Grade 9; and Mediate the strategies of teaching word problems during the provincial subject committee meetings and/or provincial curriculum meetings. Mediate and monitor the teaching of English across the curriculum to improve learner competency in word problems. 	<ul style="list-style-type: none"> Monitor the utilisation of the strategies for the teaching of word problems and provide support for teachers. Monitor the teaching of English across the curriculum to improve learner competency in word problems. 	<ul style="list-style-type: none"> The concept 'percentage' should be emphasised when dealing with common fractions and be taught in conjunction with equivalent fractions. Word problems are introduced early in Foundation Phase and similar steps of teaching word problems should be followed in Grade 9, i.e. read with understanding, underline key words, translate key words into mathematics language and then solve the problem. When teaching the concept 'decrease' or 'increase' by a percentage emphasize the calculation of percentage of a whole before subtracting or adding respectively. Involve Language teachers in the planning of lessons involving word problems.
--	--	---	--	--	---

<p>Simple interest and Compound interest: Learners could not identify and use the appropriate formula</p>	<ul style="list-style-type: none"> • Conceptual understanding of Simple interest and Compound interest should be developed during teaching. • The understanding of the formula and the meaning and purpose of each variable in the formula should be taught. • The understanding of a concept 'substitution' should be enhanced because it is one of the critical skills applied when using formulae. • Since financial mathematics is mainly dealt with in the context of word problems, the teaching of word problems should be done systematically to enhance learners' ability to interpret, understand, select critical information and use that information to calculate the answer. 	<ul style="list-style-type: none"> • Discuss during the Mathematics Subject Committee meeting to explore a possibility of providing formula sheet to Grade 9 learners during the writing of ANA. • Strengthen the DBE workbooks during the annual review to address financial mathematics adequately. 	<ul style="list-style-type: none"> • Discuss during the provincial Mathematics Subject Committee meeting to explore a possibility of providing formula sheet to Grade 9 learners during the writing of ANA. • Ensure that these topics are also dealt with adequately in EMS as part of the curriculum. • Strengthen the DBE workbooks and Sasol-Inzalo materials during the annual review to address financial mathematics adequately. 	<ul style="list-style-type: none"> • Conduct workshops on financial mathematics. • Monitor curriculum coverage. 	<ul style="list-style-type: none"> • Start by introducing a conventional method of calculating compound interest per year before introducing a formula. • Introduce a formula by explaining the meaning and purpose of the critical quantities or variables such as P, A, and r or i to enable learners to use them in the correct context. • Heads of Department (HoDs) should ensure that Simple and Compound interests are covered as part of EMS curriculum.
---	--	---	--	---	---

SENIOR PHASE (GRADES 9): MATHEMATICS

PATTERNS, FUNCTIONS AND ALGEBRA

Identified weaknesses	Remedial measures to improve classroom practice	Responsibility			
		DBE	Province	District	
Factorisation of algebraic expressions	Systematically teach the steps used in factorisation.	<ul style="list-style-type: none"> Ensure that factorisation is comprehensively addressed in all LTSMs including workbooks and Sasol-Inzalo support materials. Ensure that all teachers have a copy of CAPS for reference and guidance on how to teach factorisation. 	<ul style="list-style-type: none"> Support subject advisors during provincial meetings. Monitor curriculum implementation. Monitor the availability and utilisation of CAPS. Monitor the availability and utilisation of LTSMs including and Sasol-Inzalo support materials. 	<ul style="list-style-type: none"> Support teachers during workshops, on-site classroom visits and 1+4 Cluster work sessions. Monitor curriculum implementation and coverage. Use DBE workbooks to support teachers. Monitor the availability of CAPS to each teacher in the province. Monitor the availability and utilisation of workbooks. 	<p>Address the teaching of factorisation during the 1+4 Cluster work sessions as follows:</p> <ul style="list-style-type: none"> Start from products of whole numbers to introduce the concepts factors and factorisation. Factorisation that involves common factors, the difference of two squares and trinomials of the form $x^2 - bx + c$ should be dealt with in great detail. Systematically teach the steps used in factorisation: <ul style="list-style-type: none"> - start by checking for a common factor; - if the expression has two terms check if difference of two squares can be used; - if the expression has 3 terms factorise a trinomial; and, - if the expression has 4 terms use grouping of terms and factor out common factors.

<p>Simplifying algebraic expressions including algebraic fractions</p>	<ul style="list-style-type: none"> Start with common fractions before introducing algebraic fractions because competency in common fractions is a prerequisite for competency in algebraic fractions. Demonstrate the link between simplifying algebraic fractions and skills used in: factorisation, exponents and like and unlike terms. 	<ul style="list-style-type: none"> Ensure that algebraic expressions and algebraic fractions are comprehensively addressed in all LTSMs including workbooks and Sasol-Inzalo support materials. Ensure that all teachers have a copy of CAPS for reference and guidance on how to teach algebraic expressions and algebraic fractions. 	<ul style="list-style-type: none"> Support subject advisors during provincial meetings. Monitor curriculum implementation. Monitor the availability and utilisation of CAPS. Monitor the availability and utilisation of LTSMs including and Sasol-Inzalo support materials. 	<ul style="list-style-type: none"> Support teachers during workshops, on-site classroom visits and 1+4 Cluster work sessions. Monitor curriculum implementation and coverage. Use DBE workbooks to support teachers. Monitor the availability of CAPS to each teacher in the province. Monitor the availability and utilisation of workbooks. 	<ul style="list-style-type: none"> Teach common fractions before learners are exposed to algebraic fractions. Emphasise the rules of simplifying fractions and algebraic expressions especially when the denominators are different. Use DBE workbooks to support learners. Use CAPS to seek more clarity on the scope and methods of teaching of expressions.
--	--	--	--	--	--

<p>Algebraic equations: Difficulty solving algebraic equations involving factorisation, squaring binomials or fractions</p>	<p>Enhance the mastery of factorisation of expressions and squaring binomials as skills required for solving equations including equations involving fractions.</p>	<ul style="list-style-type: none"> Strengthen the content focusing on complex algebraic equations that involve factorisation and squaring of binomials during the annual review of DBE workbook and Sasol-Inzalo materials. Work with the Subject Committee to develop a handbook on teaching strategies and assessment activities focusing on simple and complex algebraic equations to demonstrate the application of factorisation and squaring of binomial in solving algebraic equations. 	<ul style="list-style-type: none"> Participate in the annual review of workbooks to strengthen, inter alia, the content focusing on complex algebraic equations that involve factorisation and squaring of binomials. Print, distribute and mediate the handbook developed by national Subject Committee. Utilise the provincial Subject Committees to mediate the handbook and share best practices on the teaching and assessment of algebraic equations. Monitor utilisation of the handbook. 	<ul style="list-style-type: none"> Conduct focused workshops for teachers to address the effective teaching and learning of solving algebraic equations. Monitor curriculum coverage and implementation. 	<ul style="list-style-type: none"> To strengthen the conceptual understanding of 'squaring binomials', it should be emphasised that factorising trinomials is a reverse process of a product of two binomials or squaring a binomial, e.g. $x^2 + 5x + 6 = (x + 2)(x + 3)$ because $(x + 2)(x + 3) = x^2 + 5x + 6$. Similarly $x^2 + 6x + 9 = (x + 3)^2$ because $(x + 3)^2 = x^2 + 6x + 9$. Also emphasise the fact that if $\sqrt{t} = 3$ then $t = 9$. If $x^2 + 5x + 6 = 0$ then $(x + 2)(x + 3) = 0$ which means $x + 2 = 0$ or $x + 3 = 0$ and $x = -2$ or $x = -3$.
---	---	--	--	--	---

<p>Numeric and geometric patterns</p>	<ul style="list-style-type: none"> • Teach all the different types of patterns as presented in the CAPS. • Use geometric patterns to generate a number pattern and present the pattern in a tabular form. 	<ul style="list-style-type: none"> • Strengthen numeric and geometric patterns in the workbooks and Sasol-Inzalo materials during the annual review. • Ensure that all schools have copies of CAPS because it provides critical information on the scope and strategies for the teaching of numeric and geometric patterns. • Ensure that all schools have workbooks. • Conduct monitoring to ensure effective curriculum implementation and coverage. • Use the findings of ANA diagnostic report to develop a handbook on the teaching of numeric and geometric patterns. 	<ul style="list-style-type: none"> • Print, distribute and mediate the handbook on the teaching of numeric and geometric patterns. • Support subject advisors by conducting focused workshops in this regard. • Conduct monitoring to ensure effective curriculum implementation and coverage. 	<ul style="list-style-type: none"> • Support teachers during on-site visits and/or 1+4 Cluster sessions by sharing expertise on the teaching of geometric and numeric patterns using the handbook as a resource. • Conduct regular monitoring to ensure curriculum coverage. 	<ul style="list-style-type: none"> • Teach all types of patterns presented in the CAPS. • Use geometric patterns to generate and teach number patterns. • Allow learners to generate their own patterns and describe them using own words and algebraically. • Teach the flow diagrams (input and output values) as another way to enhance the understanding of number pattern. • Emphasise the use of correct algebraic language.
---------------------------------------	---	--	---	--	---

Senior Phase (Grades 9): Mathematics

Space & Shape (Geometry)

		Responsibility			
		DBE	Province	District	School
<p>Identified weaknesses</p> <p>Triangles:</p> <ul style="list-style-type: none"> Inability to prove that two triangles are congruent. Difficulty to prove that two triangles are similar. Insufficient understanding of angle relationships such as corresponding angles. 	<p>Remedial measures to improve classroom practice</p> <ul style="list-style-type: none"> Ensure mastery of angle relationships dealt with in Straight line geometry. Strengthen conceptual understanding of congruency and similarity. 	<ul style="list-style-type: none"> Discuss during the subject committee meeting and propose the effective ways of assessing congruency and similarity, e.g. proving congruency or similarity without guidance versus filling in the missing information. Use the ANA diagnostic findings to develop a handbook on how to teach congruency and similarity. Collect, collate and distribute provincial question papers to share best practices on assessing congruency and similarity. 	<ul style="list-style-type: none"> Print and distribute the handbook on the teaching of congruency and similarity to districts. Mediate the content of the handbook to guide subject advisors on how to teach congruency and similarity. 	<ul style="list-style-type: none"> Ensure that teachers address properties of geometric figures, especially triangles, as a foundational knowledge to be applied when dealing with congruency. Ensure the concept 'proportion' is taught before introducing 'similarity' between two triangles. Monitor utilisation of the handbook to improve the teaching and assessment of congruency and similarity. 	<ul style="list-style-type: none"> Revise straight line geometry and properties of geometric figures before introducing congruency and similarity. Clearly differentiate between similarity and congruency to mitigate confusion between the two concepts. Teach the conditions of congruency and similarity. Start with simple triangles and later introduce composite or complex triangles. Expose learners to different levels of questions involving simple and complex figures, especially those that require problem solving and complex procedures.

Intermediate Phase (Grades 9): Mathematics

Measurement

Identified weaknesses	Responsibility				
	Remedial measures to improve classroom practice	DBE	Province	District	School
<p>Surface Area:</p> <ul style="list-style-type: none"> Lack of knowledge of the formula to calculate the area of a trapezium. Inability to use the Theorem of Pythagoras to determine the size of the unknown side of a triangle. 	<ul style="list-style-type: none"> The Theorem of Pythagoras can be the first step in calculations of perimeters or areas of composite figures, when one of the figures is a right-angled triangle with an unknown length. Teaching of area of complex figures should, therefore, be preceded by the teaching of this theorem. Although learners should be taught how to calculate the unknown length of a right-angled triangle, Grade 9 learners should be taught how to apply the Theorem of Pythagoras. 	<ul style="list-style-type: none"> Discuss during the Mathematics Subject Committee meeting to explore a possibility of providing formula sheet to Grade 9 learners during the writing of ANA. Ensure that the Theorem of Pythagoras is adequately addressed and high quality activities are provided in the textbooks and workbooks. 	<ul style="list-style-type: none"> Discuss during the provincial Mathematics Subject Committee meeting to explore a possibility of providing formula sheet to Grade 9 learners during the writing of ANA and make recommendation to the national Subject Committee. Develop workshop materials and conduct a workshop for subject advisors to demonstrate the importance of the Theorem of Pythagoras to calculate area of composite figures 	<ul style="list-style-type: none"> Conduct focused workshop for teacher using practical examples from real life situation to demonstrate the application of the Theorem of Pythagoras. The activities used during the workshop should be varied to cover different levels of complexity. Develop effective strategies on how to teach/introduce and apply formulae to calculate the surface area of different geometric figures including a trapezium and share them with all teachers in the 1+4 Cluster workshops. Monitor the teaching surface area and general curriculum coverage. 	<ul style="list-style-type: none"> Start by teaching the properties of a trapezium. Demonstrate that a trapezium is a composite figure that can be split into a triangle(s) and a rectangle. Teach the formulae for the area of a triangle and rectangle before introducing the formula for the area of a trapezium. Demonstrate how the area of trapezium was derived to enhance understanding.

**PART C:
DIAGNOSTIC ANALYSIS AT
SCHOOL/DISTRICT LEVELS**



Assessment provides very useful information that must be used optimally to inform effective teaching and promote purposeful learning.

Purpose of assessment and analysis

The primary purpose of assessment should be to improve learning. Schools and districts must be able to do fairly detailed diagnostic analysis of the performance of their learners or schools to identify areas of strength and challenges. After administering a test the educator can do own diagnostic analysis to identify:-

- a) The overall level of performance of the class or school;
- b) Individual learners or schools that need special intervention;
- c) Groups of learners or schools who need special support and
- d) Subject content areas that require priority attention in teaching and learning.

Use of basic statistics for analysis

Basic statistics that can be used to summarize the data from a test include the following:-

- i. Mean (often called average) – calculated by adding the scores of all the learners and dividing the sum by the number of learners. The mean is one score that is used to summarize all the scores obtained by learners in a test. A high mean score represents high performance and a low mean score represents low performance. However, the mean score does not indicate how learner scores are spread from the highest to the lowest and thus is not adequate for identifying individuals who either over-perform or under-perform.
- ii. Median (or middle score) – calculated by first arranging the scores from the highest to the lowest and then determining the score that divides the data into two equal halves. Half of the learners who wrote a test will have scores above the median score and the other half will have scores below the median score. If the number of learners is an odd number the median will be a real score that sits half-way between the extreme scores, e.g. 76, 57, 49, 45 and 39 have 49 as the median score. However, if the number of learners is an even number the median will be a score that may not belong to any of the learners calculated by adding the two adjacent scores that are half-way between the extremes and dividing their sum by two (2), e.g. the median of 76, 57, 49 and 45 is calculated by adding 57 and 49 and dividing the sum by two – $(57+49)/2=106/2=52$. As can be observed, 52 is not one of the four given scores but it is the median score that sits half-way between the extreme scores, viz. 76 and 45.

The median does not show the extreme scores, i.e. the highest and the lowest scores.

- iii. Maximum is the highest score obtained by a learner in a test.
- iv. Minimum is the lowest score obtained by a learner in a test.
- v. Range is the difference between the maximum and the minimum scores. The larger the range, the more diverse the ability levels of the test takers while a relatively small range indicates that the class of test takers has a relatively homogeneous ability profile.

Available tools for data analysis

Tools that are available for analysis of data include pre-programmed computer software such as the SA-SAMS in schools, the Microsoft Excel programme and even hand calculators. The Microsoft Excel programme, which comes

with almost every computer software, is a powerful and reasonably easy-to-use tool for performing item-level diagnostic analysis of test data. An Excel spreadsheet is arranged in columns and rows.

Preparing data for analysis on Excel

To prepare for analysis of data from an administered test, do the following:-

1. Mark the test and write the scores obtained by each learner next to the relevant question/item number in their books or scripts;
2. Enter learner names and other particulars (e.g. the gender of each learner) in the rows, one after another;
3. Enter test item numbers in the columns, one after another;
4. Enter the score of each learner on each item in the correct cell (i.e. where the relevant column and row meet);
5. Check if all data has been entered correctly (i.e. do thorough data cleaning);
6. Use correct formulae to calculate the statistics that you want to use to summarize and analyze the test data; and,
7. Interpret the statistics in terms of what they suggest about performance of individuals in your class, performance of identifiable groups of learners (e.g. males and females) and performance in specific content areas.

An example of test data (Grade 3 Mathematics) in an Excel spreadsheet is shown below. The surnames of learners, their initials and sex were entered in Rows 2 to 24, meaning there were 23 learners who wrote the test in this class. The test item/question numbers appear in Columns D to Z, a total of 23 items.

Example: Data Analysis on Excel Spreadsheet

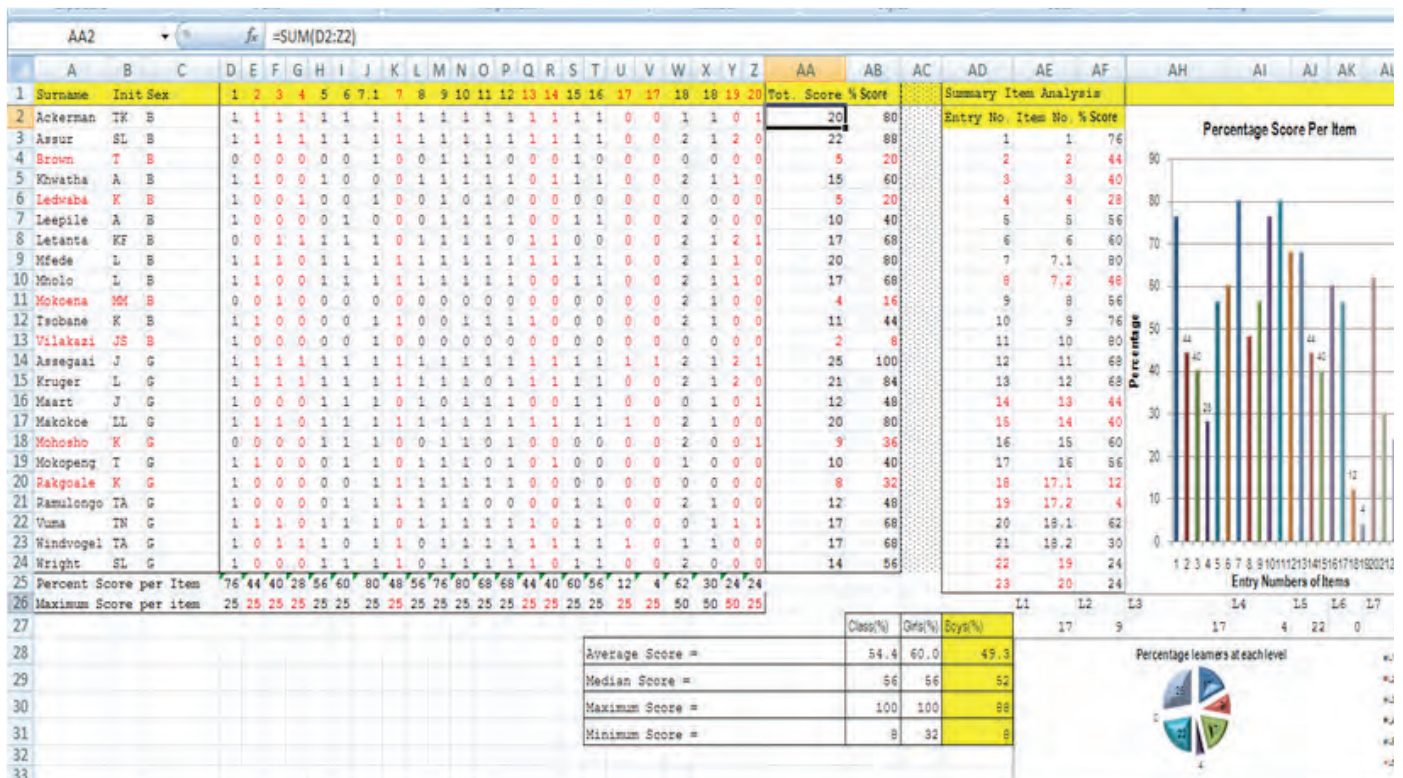

Excel makes available useful formulae to calculate basic statistics. To calculate any of the common statistics like the ones mentioned above, place the cursor in the relevant cell, enter the “=” sign followed by the first letter of the desired statistic. A menu of possible options appears and you must select the one that you want. For instance, in the spreadsheet above, to calculate the total score for the first learner in Row 2, Ackerman, TK, enter the “=” sign at the end of all the items in the test, Column AA, Cell AA2 as highlighted in the spreadsheet. Select “Sum” from the Menu, open the bracket, write D2 as the first cell with an item score, insert a colon (:) followed by the last cell with an item score for this learner, close the bracket and press “Enter”. Excel calculates the sum of all the item scores for Ackerman from D2 to Z2 (fx =SUM(D2:Z2) and places it in Cell AA2. You can repeat this process for each of the learners but you can also use the computer mouse to hold the bottom right corner of the rectangle around Cell AA2 (a cross will appear when you have placed the mouse correctly) and drag the formula from AA2 to AA24 (Little bit of practice will be required here!).

To calculate the percentage score obtained by each learner (i.e. individual learner performance) start with the first learner in Row 2, insert the “=” sign in Cell AB2, type in “AA2/25*100” to divide the score in Cell AA2 by the total score (25 in this case) and use “*” to multiply, followed by 100 for percentage (fx =AA2/25*100). You can also follow the same procedure to calculate the percentage score for each learner or you can use the “dragging” technique outlined above.

To calculate the percentage scores obtained on each item (i.e. performance of all learners on each item), start by typing in the maximum scores per item as in Row 26. To calculate the total score obtained by learners in Item 1 (Column D) type in the “=” sign in Cell D25 followed by “Sum(D2:D24)/25*100”. Excel calculates the sum of learner scores in Item 1, divides it by the Maximum score for this item (25) and multiplies that by 100 to convert the answer to a percentage (76% in this case). Do the same for each of the following items or use the “dragging” technique described above. Note that for items that have a different total (e.g. 50 instead of 25) you must use the relevant total.

Analysis and interpretation

To summarize the data calculate the average percentage score, the median, maximum and minimum score percentages also, do this separately for boys and girls.

To make sense of the analysis it is recommended that different colour codes be used to mark specific observations (Excel provides a wide range of colour codes) and also represent findings with appropriate graphs to enhance visual impressions to aid decision-making on where to focus improvement interventions. For instance, the following observations can be made from the analysis that has been done in the example spreadsheet above:

a) Overall performance

Overall performance in this class, measured through the mean score, was 54,4% which was relatively acceptable but still leaves room for improvement. The median score for the class was 56% which means that half of the learners obtained scores above 56% and another half obtained scores below 56%.

b) Performance spread

Although the mean and median scores were both above 50%, learner scores ranged between eight percent (8%) and 100% which is a fairly wide range that suggests diverse abilities in this class. This implies that intervention strategies will have to be diversified in order to meet the learning needs of different learners, i.e. a one-size-fits-all improvement strategy will not work in this class.

c) Individual learner differences in performance

Individual learners who were identified to be particularly at risk have been indicated with red colour coding. They obtained scores below 40% and thus fall within the “Not achieved” and “Elementary achievement” levels. They require special attention in terms of teaching strategies and learning opportunities.

d) Group differences in performance

Analysis was done at two group levels, viz. boys and girls. All the summary statistics indicate that the boys performed much lower than the girls. Their mean score was 49,3% against the 60% mean score obtained by girls. The median score for the boys was four percent (4%) lower than that of the girls, viz. 52% as against 56%. Boys' scores ranged between eight percent (8%) and 88% while the lowest score for the girls was 32% and the highest was 100%. Boys need intervention to bring them to the level required for them to perform or excel, without neglecting the girls.

e) Performance in specific content areas

The percentage scores per item indicate the items and, therefore, the content areas where interventions must focus.

The analysis and diagnosis (from a to e above) identify

- i. Which learners need special attention; and,
- ii. Which content areas require special focus.

The analysis also suggests materials required to improve on the identified areas, the extra support the teacher will need (if necessary), whether additional time will be required, who else should be involved in the interventions and a host of other possibilities that the data analyzer may see fit in their context.

SUMMARY

In summary diagnostic analysis of assessment data must be conducted regularly at all levels of the system, particularly at the classroom level. The purpose of the analysis and diagnosis is to assess whether learning goals are being achieved by all learners so that every learner has ample opportunity to succeed. Different tools are available for conducting an analysis. In particular, the use of Excel spreadsheets generates simple but powerful statistics for summarizing assessment data. The excel programme also provides graphs and other visual representations of data that enhance the quality of reports and thus aid data interpretation. All analysis needs to be followed by a plan of action on how the identified weaknesses will be addressed. The plan of action will include appropriate improvement plans at classroom, school and district levels.



Published by the Department of Basic Education

222 Struben Street

Private Bag X895, Pretoria, 0001

Telephone: 012 357 3000 Fax: 012 323 0601

ISBN: 978-1-4315-2046-6

© Department of Basic Education

website

www.education.gov.za

facebook

www.facebook.com/BasicEd

twitter

www.twitter.com/dbe_sa